

Lenze

**ELTRA TRADE S.R.O.
SUPPLIES FULL RANGE OF
LENZE PRODUCTS**



The best prices



The highest level of
technical support



Customers from over
120 countries



The fastest supply

We provide the best prices and delivery terms for the following Lenze equipment:



**FREQUENCY
INVERTERS**

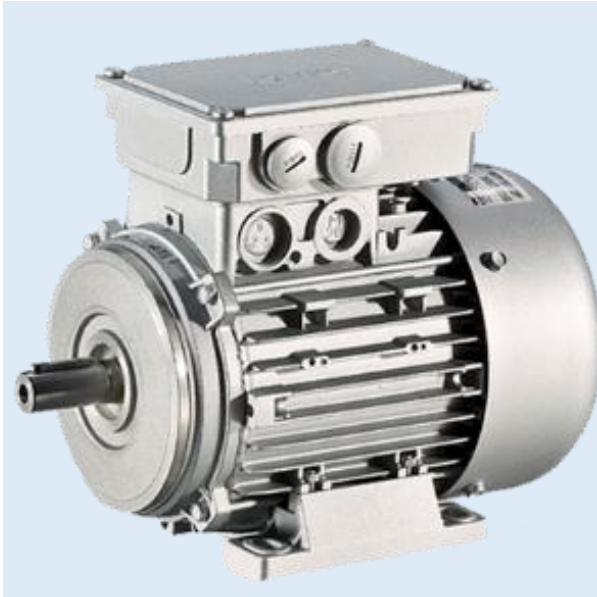

MOTORS

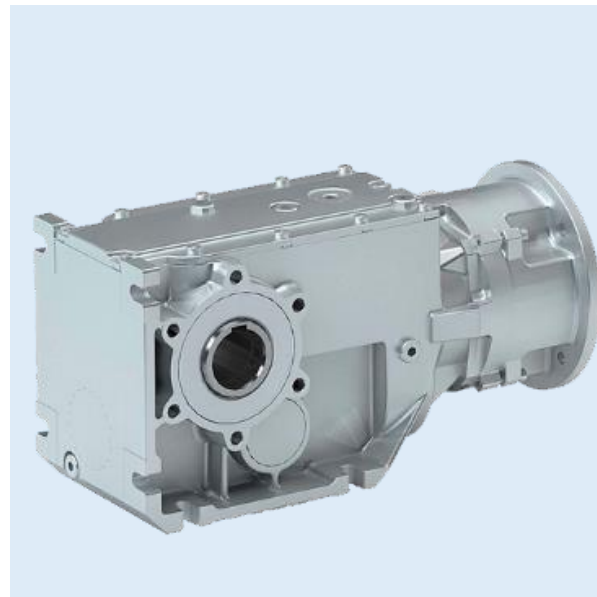

GEARBOXES



CONTROLS

INDUSTRIES & APPLICATIONS

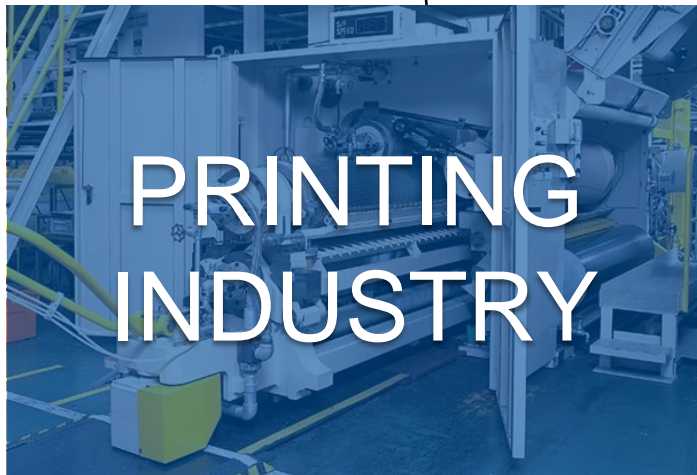
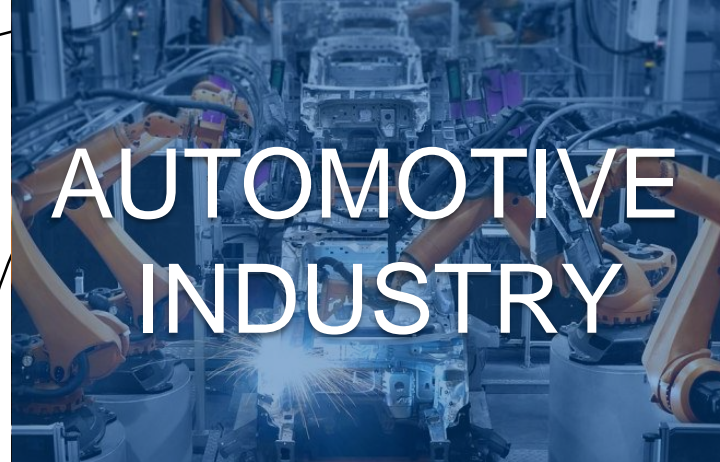

FREQUENCY INVERTERS

THE MAIN SERIES:

- Lenze 8200
- Lenze 8400
- Lenze 9300
- Lenze 9400
- Lenze SMD
- Lenze SMV



Lenze's inverters are the right solution for speed and torque-controlled motion

THE MAIN TYPES



DECENTRALIZED
INVERTERS



CABINET
INVERTERS



CABINET SERVO
INVERTERS

8200

FEATURES:

- Application-Oriented Functions
- Compact Design
- Internal Functions Reduce Complexity
- Minimum Space Requirement
- Single Phase
- Easy Operation and Assembly



8400

FEATURES:

- Operating temperature: -10...+55 °C
- Degree of protection IP20
- L-force diagnostic connector for diagnostics and parameterization
- PID controller
- Automatic engine identification



9300

FEATURES:

- Various Mountings
- Multiple Power Ratings
- Several Variants
- Regulation of the distance traveled
- Digital frequency connection
- Expansion slot for communication modules



9400

FEATURES:

- Integrated brake control
- Supports synchronous and asynchronous motors
- Scalable memory with multiple memory modules
- Scalable Security Feature



SMD

FEATURES:

- DC braking
- Temperature control of the electric motor
- Manual speed adjustment
- Compact sizes
- 3 set speeds



SMV

FEATURES:

- Built-in PID controller
- 8 preset speeds
- Speed reference 4-20mA
- DC braking
- Relay or transistor output
- 3 or more programmable inputs



MOTORS

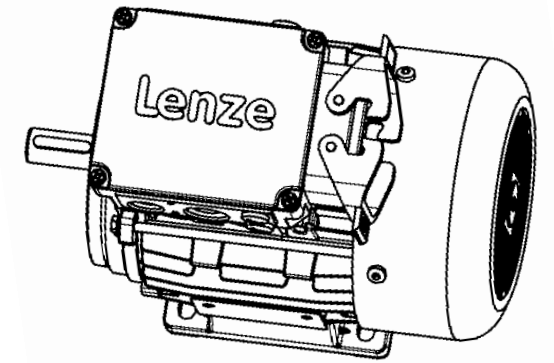

The company produces both asynchronous and synchronous motors

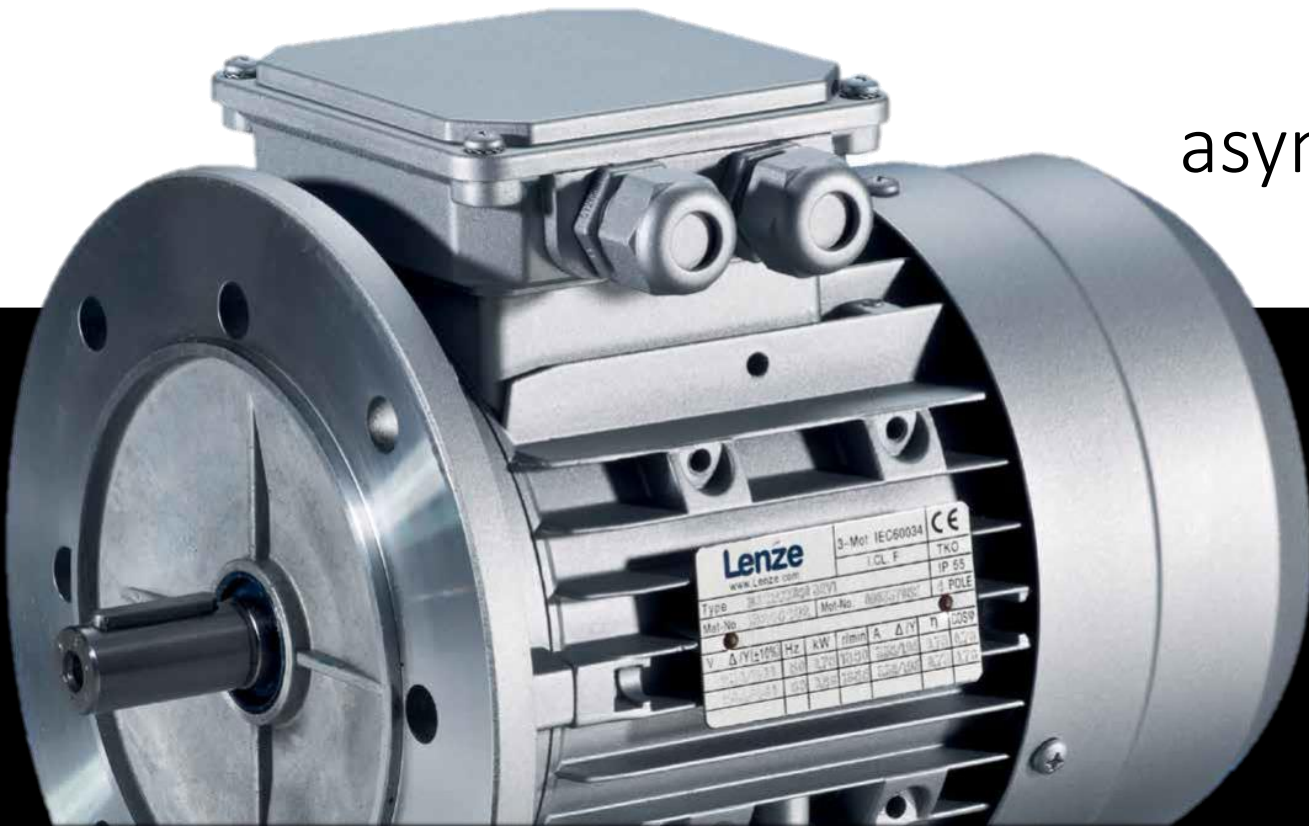

Lenze motors is the right solution with optimum drive behavior and application-oriented options

MOTOR TYPES

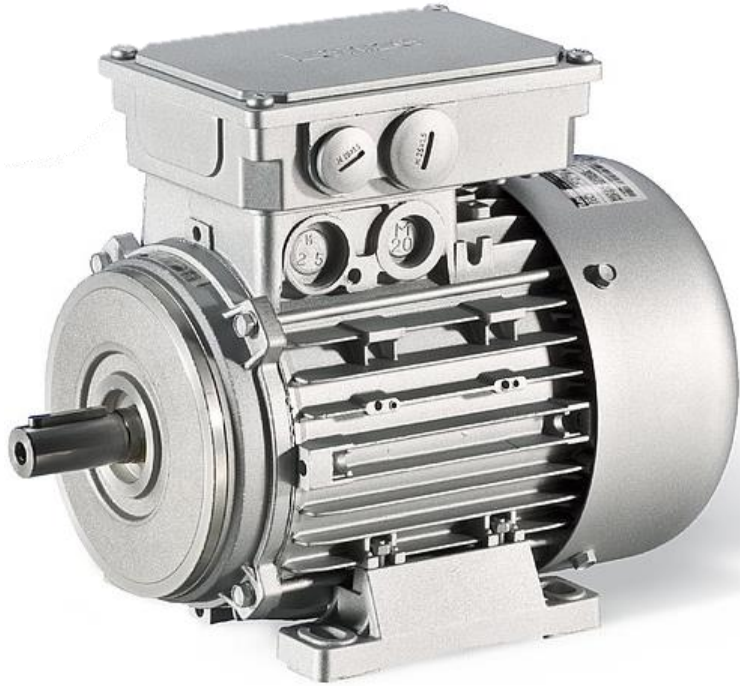

INVERTER-OPERATED
3-PHASE AC MOTORS



SERVO MOTORS

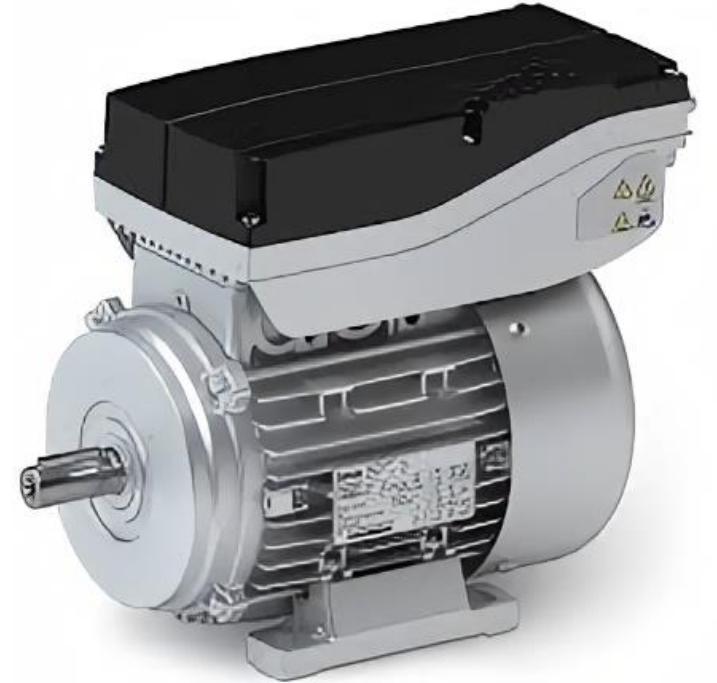

MAINS-OPERATED
3-PHASE AC MOTORS

GEARBOXES

ADVANTAGES:

- Power range up to 45 Kw
- Optimized drive package that meets very high requirements

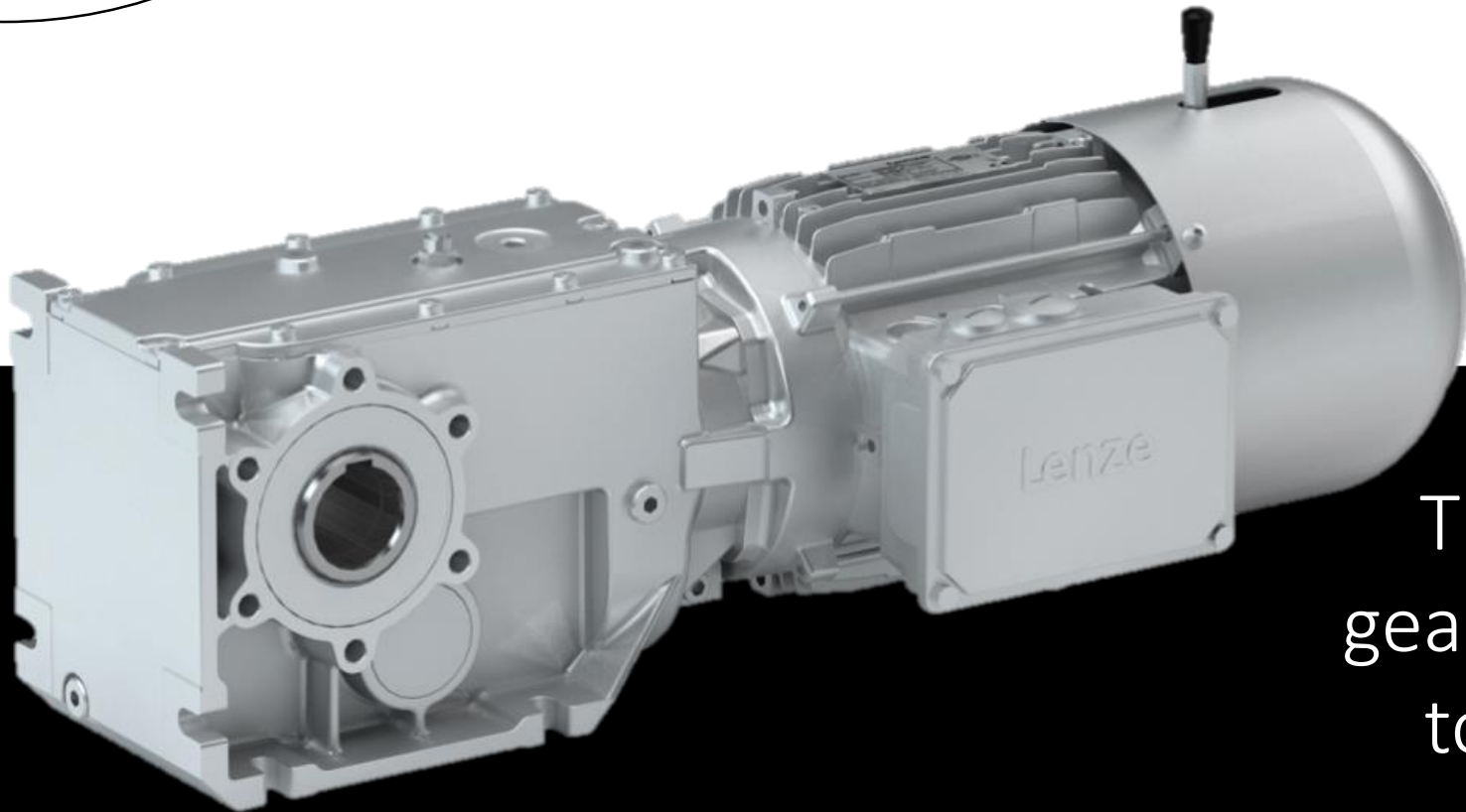

The robust, efficient Lenze gearboxes can handle even the toughest of machine tasks

GEARBOX TYPES

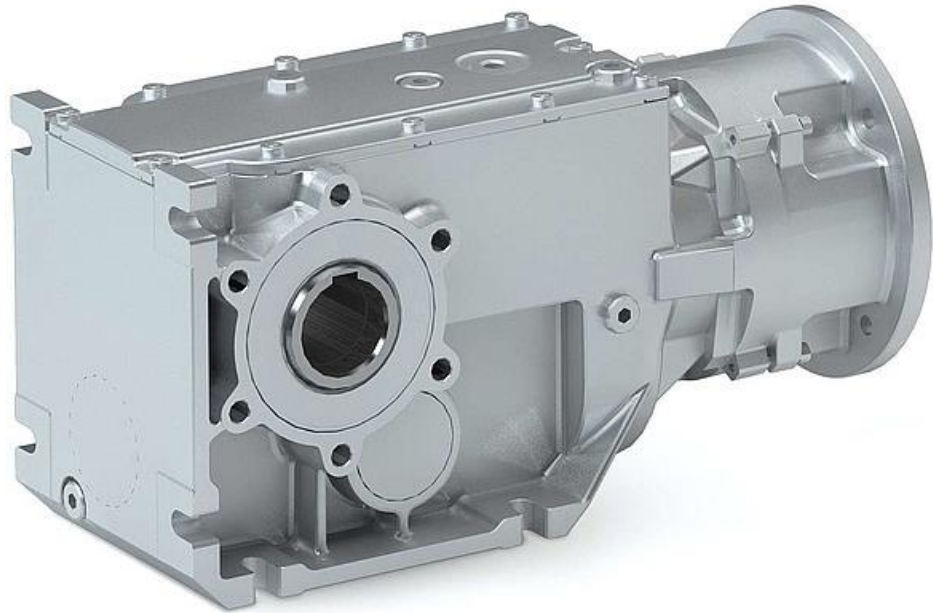

**RIGHT-ANGLE
GEARBOXES**



**AXIAL
GEARBOXES**

RIGHT-ANGLE GEARBOXES

- G500-B bevel gearboxes

- G350-B smart geared motor

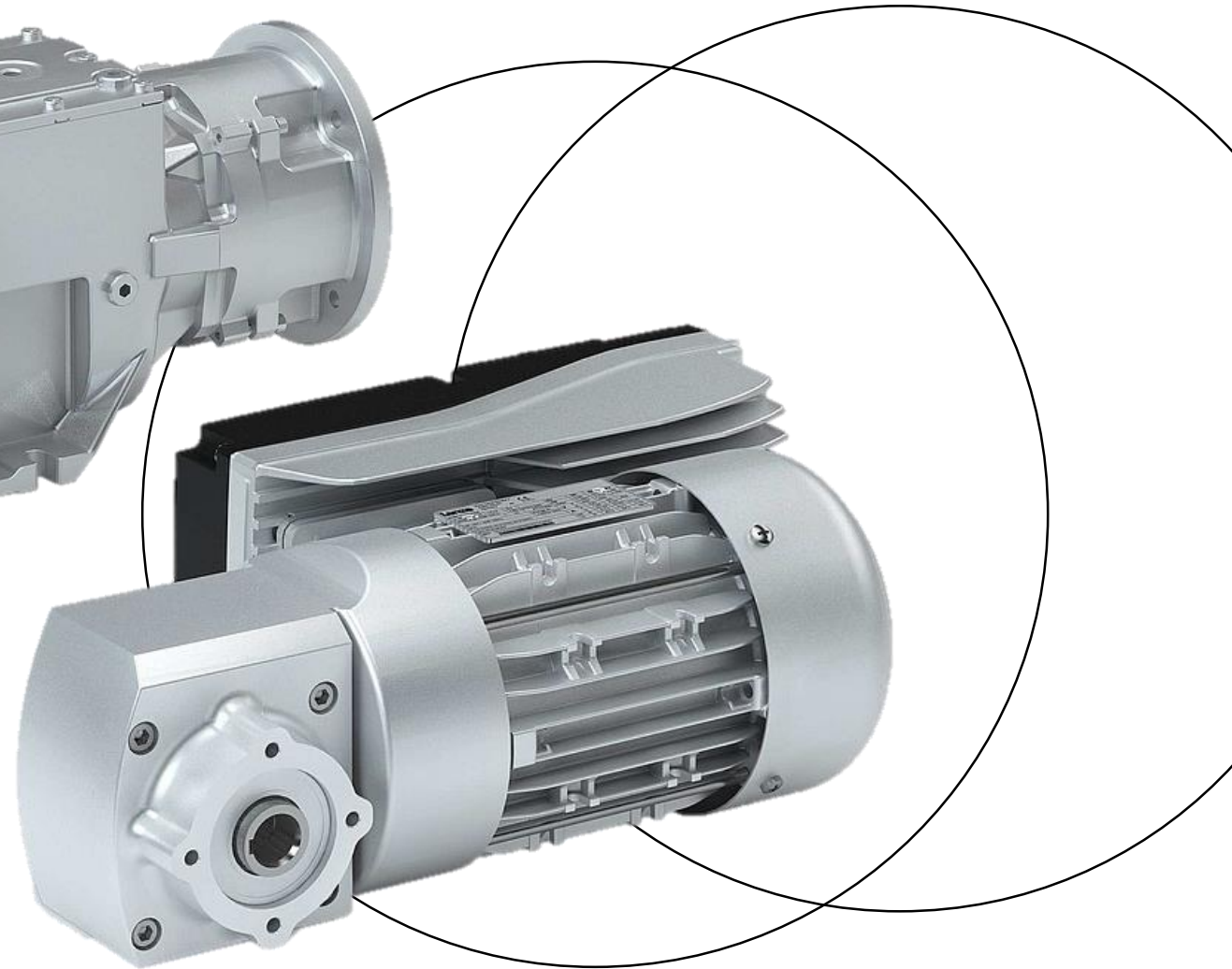
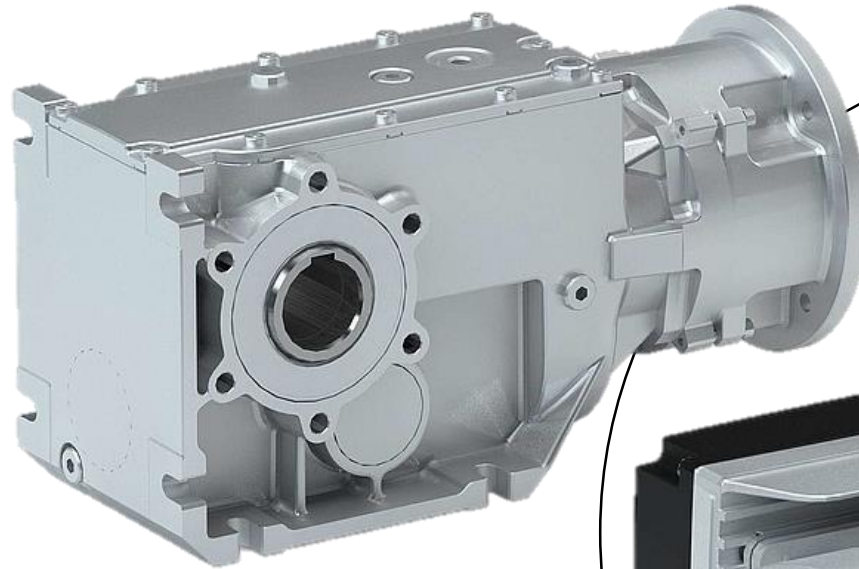

AXIAL GEARBOXES

G7X0/G8X0
planetary gearboxes
and bevel planetary
gearboxes



MPR/MPG planetary
gearboxes



G500-H helical
gearboxes



G500-S shaft-
mounted helical
gearboxes



CONTROLS

ADVANTAGES:

- Coordinated interfaces
- Optimized runtimes
- Compact engineering



Full range of controlling components: from event-controlled controlling to full machine automation

CONTROL TYPES



PANEL & CABINET
CONTROLLERS

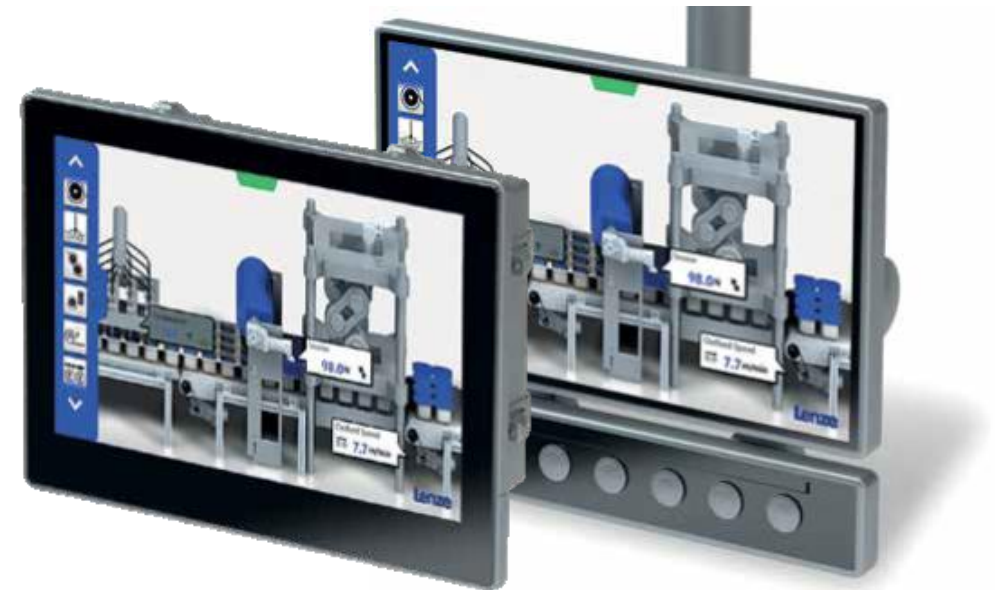

VISUALIZATION

CONTROLLERS & VISUALIZATION

- Industrial PC v800-C
Industrial PC v800-P
Monitor v200-P



- Industrial PC v800-P



- Controllers c500



- Controller p500



- Controller 3200 C



- Monitor panels



CONTROLLERS

● Controller p300



● Controller c300



● Safety Controller c250-S



● I/O system 1000



ABOUT US



Eltra Trade s.r.o. is fast developing company in supplying industrial automation equipment

Serving customers in over 100 countries we help them to improve their energy efficiency and enhance productivity level

Thanks to long-standing contacts with our suppliers we can provide the fastest supply and the best prices on wide range of equipment

Highest flexibility, trust and credibility are the main principles of our company



Shipping anywhere in the world



www.eltra-trade.com



+421 552 601 099



info@eltra-trade.com