



SITRANS MAG 1100/1100 F





Siemens mag 1100 is a wafer design electromagnetic flowmeter with stainless steel housing, designed specifically for use in extreme production conditions.

Siemens produces following Magflo 1100 models:

- Mag 1100 (standard version)
- Mag 1100 (for food industry)
- Mag 1100 (for high temperature)

Presented flowmeter range has a number of advantages of the SITRANS series. The device is fully compatible with Plug & Play technology and "Hot swappable" which allows quickly installing and reinstalling all equipment. Series has a wafer design that meets the standards of EN 1092, DIN and ANSI, and can be installed in a compact or separate way.

To find out stock ability and delivery time to your region, please contact our manager.



info@eltra-trade.com

SIEMENS

SITRANS F

Electromagnetic flowmeters SITRANS MAG 1100/1100 F

Operating Instructions

<u>Introduction</u>	1
<u>Safety notes</u>	2
<u>Description</u>	3
<u>Installing/Mounting</u>	4
<u>Connecting</u>	5
<u>Service and maintenance</u>	6
<u>Troubleshooting</u>	7
<u>Technical data</u>	8
<u>Appendix</u>	A

7ME611 (MAG 1100)
7ME612 (MAG 1100 HT)
7ME614 (MAG 1100 F)

Legal information

Warning notice system

This manual contains notices you have to observe in order to ensure your personal safety, as well as to prevent damage to property. The notices referring to your personal safety are highlighted in the manual by a safety alert symbol, notices referring only to property damage have no safety alert symbol. These notices shown below are graded according to the degree of danger.

DANGER

indicates that death or severe personal injury **will** result if proper precautions are not taken.

WARNING

indicates that death or severe personal injury **may** result if proper precautions are not taken.

CAUTION

indicates that minor personal injury can result if proper precautions are not taken.

NOTICE

indicates that property damage can result if proper precautions are not taken.

If more than one degree of danger is present, the warning notice representing the highest degree of danger will be used. A notice warning of injury to persons with a safety alert symbol may also include a warning relating to property damage.

Qualified Personnel

The product/system described in this documentation may be operated only by **personnel qualified** for the specific task in accordance with the relevant documentation, in particular its warning notices and safety instructions. Qualified personnel are those who, based on their training and experience, are capable of identifying risks and avoiding potential hazards when working with these products/systems.

Proper use of Siemens products

Note the following:

WARNING

Siemens products may only be used for the applications described in the catalog and in the relevant technical documentation. If products and components from other manufacturers are used, these must be recommended or approved by Siemens. Proper transport, storage, installation, assembly, commissioning, operation and maintenance are required to ensure that the products operate safely and without any problems. The permissible ambient conditions must be complied with. The information in the relevant documentation must be observed.

Trademarks

All names identified by ® are registered trademarks of Siemens AG. The remaining trademarks in this publication may be trademarks whose use by third parties for their own purposes could violate the rights of the owner.

Disclaimer of Liability

We have reviewed the contents of this publication to ensure consistency with the hardware and software described. Since variance cannot be precluded entirely, we cannot guarantee full consistency. However, the information in this publication is reviewed regularly and any necessary corrections are included in subsequent editions.

Table of contents

1	Introduction.....	5
1.1	Purpose of this documentation.....	5
1.2	Document History.....	5
1.3	Items supplied.....	5
1.4	Checking the consignment.....	6
1.5	Device identification.....	6
1.6	Further Information.....	7
1.7	Security information.....	7
1.8	Transportation and storage.....	8
1.9	Notes on warranty.....	8
2	Safety notes.....	9
2.1	Laws and directives.....	9
2.2	Installation in hazardous area.....	11
2.3	Certificates.....	13
3	Description.....	15
3.1	Applications.....	15
3.2	System components.....	15
3.3	Design.....	16
3.4	Theory of operation.....	17
4	Installing/Mounting.....	19
4.1	Installation safety precautions.....	19
4.2	Determining a location.....	20
4.3	Installation in partially filled pipes.....	21
4.4	Orienting the sensor.....	23
4.5	Mounting MAG 1100/1100 HT.....	24
4.6	Mounting MAG 1100 F.....	27
4.6.1	Mounting with a welding type adapter.....	29
4.6.2	Mounting with a clamp type adapter.....	29
4.6.3	Mounting with a threaded type adapter.....	30
4.7	Torques values.....	30
4.8	Potential equalization.....	31

Table of contents

5	Connecting.....	33
5.1	General safety requirements.....	33
5.2	Remote installation.....	35
5.3	Installation check.....	38
5.4	Potting.....	39
6	Service and maintenance.....	41
6.1	Maintenance.....	41
6.2	Recalibration.....	41
6.3	Unit repair.....	41
6.4	Technical support.....	42
6.5	Return procedures.....	42
6.6	Disposal.....	43
7	Troubleshooting.....	45
7.1	Improving the application.....	45
7.2	Sensor check.....	45
7.3	Fluctuating process values.....	47
8	Technical data.....	49
8.1	Process connections.....	49
8.2	Rated operating conditions.....	50
8.3	Temperature shock.....	50
8.4	Design.....	52
8.5	Liner.....	52
8.6	Electrodes.....	53
8.7	Cable entries.....	53
8.8	Cable data.....	53
8.9	Pressure / temperature range.....	55
8.10	Process fluid conductivity.....	56
8.11	Dimensions and weight.....	57
8.12	Accessories for MAG 1100 F.....	62
8.13	Certificates and approvals.....	65
A	Appendix.....	67
A.1	Factory settings.....	67
A.2	Coil resistance.....	68
A.3	Ordering of spare parts.....	69
	Index.....	71

Introduction

1.1 Purpose of this documentation

These instructions contain all information required to commission and use the device. Read the instructions carefully prior to installation and commissioning. In order to use the device correctly, first review its principle of operation.

The instructions are aimed at persons mechanically installing the device, connecting it electronically, configuring the parameters and commissioning it, as well as service and maintenance engineers.

1.2 Document History

The contents of these instructions are regularly reviewed and corrections are included in subsequent editions. We welcome all suggestions for improvement.

The following table shows the most important changes in the documentation compared to each previous edition.

Edition	Remarks
08/2018	Corrections to dimensions and weight
01/2018	The Operating Instructions now includes MAG 1100 F Updated introduction
05/2016	Updated connecting/remote installation Updated dimension-dependent factory settings Updated coil resistance table
02/2011	First edition The Operating Instructions replaces: <ul style="list-style-type: none"> • MAG 1100 part of SITRANS F M HANDBOOK (A5E02435647) • SITRANS F M MAG 1100 DN 2- DN 100 • SITRANS F M MAG 1100 DN 2- DN 3

1.3 Items supplied

- SITRANS F M MAG 1100/1100 F
- Calibration report
- DVD with documentation and certificates
- Safety Note

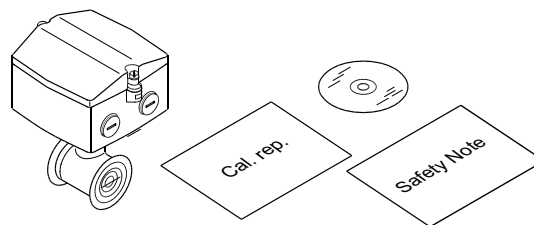

1.4 Checking the consignment

1. Check the packaging and the delivered items for visible damages.
2. Report any claims for damages immediately to the shipping company.
3. Retain damaged parts for clarification.
4. Check the scope of delivery by comparing your order to the shipping documents for correctness and completeness.



WARNING

Using a damaged or incomplete device

Risk of explosion in hazardous areas.

- Do not use damaged or incomplete devices.

1.5 Device identification

Inspection

1. Check for mechanical damage due to possible improper handling during shipment. All claims for damage are to be made promptly to the shipper.
2. Make sure the scope of delivery, and the information on the type plate correspond to the ordering information

Identification

SIEMENS	
SITRANS F M MAG 1100	
① Order No.:	7ME61102RB202BA3
② Serial No.:	007421H028
③ Size DN: 40 (1½ inch.) Lining: Ceramic	MAWP (PS) at -20°C/-4°F : 40bar/580psi
④ Sensor material: AISI 316L / 1.4404	MAWP (PS) at 150°C/302°F: 40bar/580psi
⑤ Electrodes: Platinum	T.media min.: -20°C/-4°F
⑥ Cal. factor: 1.06888998	T.media max.: 150°C/302°F
⑦ Fluid group: PED/G1	Process connect.: Weld in, DIN 11850
	Year of Manuf.: 2016
	Input 60V max. 0.125A max.
Siemens A/S Flow Instruments, 6400 Soenderborg, Denmark	
Made in France	

- | | | |
|---|---------------------|---|
| ① | Product name | Sensor product name |
| ② | System order no. | Device-specific system order number |
| ③ | Material | Sensor material |
| ④ | Cal. Factor | Calibration factor |
| ⑤ | Fluid group | Fluid group statement required by PED |
| ⑥ | Lining | Liner type Ceramic |
| ⑦ | MAWP | Maximum allowable working pressures at -20 °C (-4 °F) and 150 °C (302 °F) |
| ⑧ | Tmedia | Process media temperature |
| ⑨ | Year of Manufacture | Manufacturing year |

network or the internet if and to the extent necessary and with appropriate security measures (e.g. use of firewalls and network segmentation) in place.

Additionally, Siemens' guidance on appropriate security measures should be taken into account. You can find more information about industrial security by visiting:
<https://www.siemens.com/industrialsecurity>.

Siemens' products and solutions undergo continuous development to make them more secure. Siemens strongly recommends you apply product updates as soon as available and always use the latest product versions. Use of product versions that are no longer supported, and failure to apply latest updates may increase customer's exposure to cyber threats.

To stay informed about product updates, subscribe to the Siemens Industrial Security RSS Feed under
<https://www.siemens.com/industrialsecurity>.

1.8 Transportation and storage

To guarantee sufficient protection during transport and storage, observe the following:

- Keep the original packaging for subsequent transportation.
- Devices/replacement parts should be returned in their original packaging.
- If the original packaging is no longer available, ensure that all shipments are properly packaged to provide sufficient protection during transport. Siemens cannot assume liability for any costs associated with transportation damages.

NOTICE

Insufficient protection during storage

The packaging only provides limited protection against moisture and infiltration.

- Provide additional packaging as necessary.

Special conditions for storage and transportation of the device are listed in Technical data (Page 49).

1.9 Notes on warranty

The contents of this manual shall not become part of or modify any prior or existing agreement, commitment or legal relationship. The sales contract contains all obligations on the part of Siemens as well as the complete and solely applicable warranty conditions. Any statements regarding device versions described in the manual do not create new warranties or modify the existing warranty.

The content reflects the technical status at the time of publishing. Siemens reserves the right to make technical changes in the course of further development.

Safety notes

CAUTION

Correct, reliable operation of the product requires proper transport, storage, positioning and assembly as well as careful operation and maintenance.

Only qualified personnel should install or operate this instrument.

Note

Alterations to the product, including opening or improper modifications of the product are not permitted.

If this requirement is not observed, the CE mark and the manufacturer's warranty will expire.

2.1 Laws and directives

General requirements

Installation of the equipment must comply with national regulations. For example EN 60079-14 for the European Community.

Instrument safety standards

The device has been tested at the factory, based on the safety requirements. In order to maintain this condition over the expected life of the device the requirements described in these Operating Instructions must be observed.

NOTICE

Material compatibility

Siemens Flow Instruments can provide assistance with the selection of wetted sensor parts. However, the full responsibility for the selection rests with the customer and Siemens Flow Instruments can take no responsibility for any failure due to material incompatibility.

CE marked equipment

The CE-mark symbolizes the compliance of the device with the following directives:

- EMC-directive 89/336/EWG
- Low voltage directive 73/23/EWG

Safety notes

2.1 Laws and directives

- Pressure equipment directive (PED/DGRL) 93/23/EG
- ATEX Directive 94/9/EG

PED directive

Pressure Equipment Directive" (PED) is mandatory for all pressure equipment sold within the EU and EFTA.

Siemens Flow Instruments products comply with PED as stated in the following table.

Table 2-1 MAG 1100 and MAG 1100 HT PED compliance

Flange mm	MAG 1100		MAG 1100 HT	MAG 1100 F	
	Ceramic	PFA	Ceramic	Ceramic	PFA
2	EXC.PED	N/A	N/A	N/A	N/A
3	EXC.PED	N/A	N/A	N/A	N/A
6	EXC.PED	N/A	N/A	N/A	N/A
10	EXC.PED	EXC.PED	N/A	EXC.PED	EXC.PED
15	EXC.PED	EXC.PED	EXC.PED	EXC.PED	EXC.PED
25	EXC.PED	EXC.PED	EXC.PED	EXC.PED	EXC.PED
40	PED	EXC.PED	PED	PED	EXC.PED
50	PED	PED	PED	PED	PED
65	PED	PED	PED	PED	PED
80	PED	PED	PED	PED	PED
100	PED	PED	PED	PED	PED

Siemens Flow Instruments products confirms to PED by following the tables below.

EXC. PED = Excluded from PED under SEP or LVD

PED= Product covered by PED

N/A= Size/pressure outside of PED scope or not available in the size range

 **CAUTION**

All products sold outside of EU and EFTA are excluded from the Pressure Equipment directive, also products sold into certain market sectors are excluded. These include

1. Meters used in networks for the supply, distribution and discharge of water.
2. Meters used in pipelines for the conveyance of any fluid from offshore to onshore.
3. Meters used in the extraction of petroleum or gas, including christmas tree and manifold equipment.
4. Any meter mounted on a ship or mobile offshore platform.

2.2 Installation in hazardous area

WARNING

Equipment used in hazardous areas must be Ex-approved and marked accordingly.

It is required that the special conditions for safe use provided in the manual and in the Ex certificate are followed!

Hazardous area approvals

The device is approved for use in hazardous area and has the following approval:

- II 2 (1) GD Ex e ia IIB T3-T6 (MAG 1100 Ex remote mounted)
- II 2 (1) (2) GD Ex d [ia] [ib] IIB T3-T6 (MAG 1100 Ex compact mounted with MAG 6000 I Ex de)

WARNING

Make sure the hazardous area approval is suitable for the environment in which the device will be installed.

Intrinsically safe data

Table 2-2 Intrinsically safe data for remote mounted MAG 1100 Ex

Coil circuit "Ex e" (Terminal 85,86)

U _i	30 V (70 V peak)
I _i	130 mA

WARNING

Compact mounted versions

For intrinsically safe data for MAG 3100 Ex compact mounted with MAG 6000 I Ex d, refer to the Operating Instructions of MAG 6000 I or to certificate number Sira 07ATEX3181X, available here: Sira certificate (<https://support.industry.siemens.com/cs/document/43032182/for-use-in-hazardous-locations-atex-ec-type-examination-certificate-sira?dti=0&pnid=17323&lc=en-WW>).

WARNING

With intrinsically safe circuits, use only certified meters appropriate for the transmitter.

If a non-conforming supply unit is used, the "fail-safe" type of protection will no longer be effective and the approval certification will be invalid.

Temperature specifications for Ex use

Maximum process fluid temperature [°C]	Maximum process fluid temperature [°C]	Ambient temperature [°C]
67	T6 (85 °C)	-25 to +60
82	T5 (100 °C)	-25 to +60
117	T4 (135 °C)	-25 to +60
180 (Remote configuration)	T3 (200 °C)	-25 to +60
150 (Compact configuration)	T3 (200 °C)	-25 to +50

For dust protection, the surface temperature is equal to the process fluid temperature plus 5 °C

Special conditions for safe use

It is required that:

Electrical connections are in accordance with IEC/EN60079-14 (Installing Electrical Systems in Explosion Hazardous Areas).

- The protective cover over the power supply is properly installed. For intrinsically safe circuits the connection area can be opened.
- Appropriate cable connectors are used for the output circuits:
 - Intrinsically safe: blue
 - Non-intrinsically safe: black
- Sensor and transmitter are connected to the potential equalization. For intrinsically safe output circuits potential equalization must be maintained along the entire connection path.
- Sensor insulation thickness is max. 100 mm (only insulated sensors).
- EN50281-1-2 is considered for installation in areas with combustible dust.
- When protective earth (PE) is connected, no potential difference between the protective earth (PE) and the potential equalization (PA) can exist, even during a fault condition.

WARNING

"Flameproof enclosure" type of protection

Only open devices with type of protection "Flameproof enclosure" in hazardous areas when the power to the device is turned off, otherwise there is a risk of explosion.

WARNING

Laying of cables

Cable for use in zone 1 and 2 or 21 and 22 must satisfy the requirements for having a proof voltage < AC 500 V applied between the conductor/ground, conductor/shield and shield/ground.

Connect the devices that are operated in hazardous areas as per the stipulations applicable in the country of operation, e.g. for Ex "d" and "nA", permanent cables must be laid.

2.3 Certificates

You can find certificates on the Internet at online support portal (<http://www.siemens.com/processinstrumentation/certificates>) or on an included DVD.

See also

Technical data (Page 49)

Description

3.1 Applications

The pulsed DC-powered magnetic flowmeters are suitable for measuring the flow of almost all electrically conductive liquids, pastes, and slurries with max. 40% solids.

The main applications can be found in the following sectors:

- Water and waste water
- Chemical and pharmaceutical industries
- Food & beverage industry
- Mining and cements industries
- Pulp and paper industry
- Steel industry
- Power generation; utility and chilled water industry

WARNING

This is a Class A product

In a domestic environment this product may cause radio interference in which case the user may be required to take adequate measures.

3.2 System components

The SITRANS F M flowmeter system includes:

- Transmitter (types: SITRANS F M MAG 5000/6000 or MAG 6000 I)
- Sensor (types: SITRANS F M MAG 1100/1100 F, MAG 3100/3100 P or MAG 5100 W)
- Communication module (optional) (types: HART, PROFIBUS PA/DP, MODBUS RTU RS 485, Foundation Fieldbus H1, Devicenet)
- SENSORPROM memory unit

Communication solutions

The SITRANS F M range of add-on modules, presently including HART, Foundation Fieldbus, MODBUS RTU RS 485, PROFIBUS PA / DP and Devicenet, are all applicable with the SITRANS F M MAG 6000 transmitter.

3.3 Design

The SITRANS F M MAG 1100 is an electromagnetic flow sensor in a compact wafer design designed for flow applications in the process industry.



MAG 1100



MAG 5000



MAG 6000I

Sensor housing and flanges are designed in carbon steel (ASTM A 105) and terminal box in fibre glass reinforced polyamide or optionally in stainless steel (AISI 316). Measuring pipe is made of stainless steel (AISI 304) while liners and electrodes are available in various materials, making the sensor highly resistant to a wide range of chemicals.

The present range of liner types includes:

- PFA
- Ceramic
- EPDM

Electrodes are available in:

- Hastelloy C276 or C22
- AISI 316 / 1.4571
- Platinum / platinum with gold/Titanium brazing alloy

The sensors carry a wide range of approvals, see Technical data (Page 49).

3.4 Theory of operation

The flow measuring principle is based on Faraday's law of electromagnetic induction.

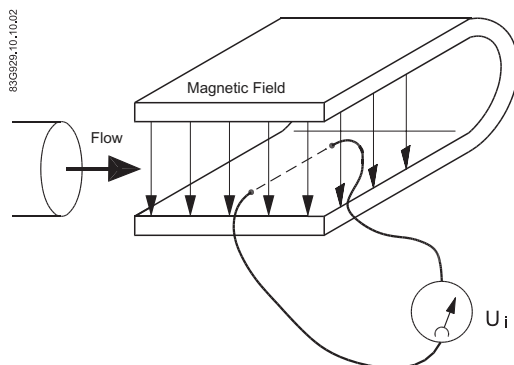

U_i = When an electrical conductor of length L is moved at velocity v , perpendicular to the lines of flux through a magnetic field of strength B , the voltage U_i is induced at the ends of the conductor

$$U_i = L \times B \times v$$

- U_i = Induced voltage
- L = Conductor length = Inner pipe diameter = k_1
- B = Magnetic field strength = k_2
- v = Velocity of conductor (media)
- $k = k_1 \times k_2$

$U_i = k \times v$, the electrode signal is directly proportional to the fluid velocity

Operating principle

The coil current module generates a pulsating magnetizing current that drives the coils in the sensor. The current is permanently monitored and corrected. Errors or cable faults are registered by the self-monitoring circuit.

The input circuit amplifies the flow-proportional induced voltage signal from the electrodes. The input impedance is extremely high: $>10^{14} \Omega$ which allows flow measurements on fluids with conductivities as low as $5 \mu\text{S/cm}$. Measuring errors due to cable capacitance are eliminated due to active cable screening.

The digital signal processor converts the analog flow signal to a digital signal and suppresses electrode noise through a digital filter. Inaccuracies in the transmitter as a result of long-term drift and temperature drift are monitored and continuously compensated for via the self-monitoring circuit. The analog to digital conversion takes place in an ultra low noise ASIC with 23 bit signal resolution. This has eliminated the need for range switching. The dynamic range of the transmitter is therefore unsurpassed with a turn down ratio of minimum 3000:1.

3.4 Theory of operation

Installing/Mounting

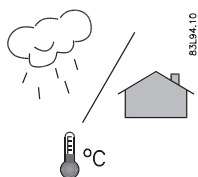

SITRANS F flowmeters with minimum IP65/NEMA 4X enclosure rating are suitable for indoor and outdoor installations.

- Make sure that pressure and temperature specifications indicated on the device nameplate / label will not be exceeded.

WARNING

Installation in hazardous location

Special requirements apply to the location and interconnection of sensor and transmitter. See Installation in hazardous area (Page 11)

4.1 Installation safety precautions

WARNING

High pressure hazard

In applications with working pressures/media that can be dangerous to people, surroundings, equipment or others in case of pipe fracture, we recommend that special precautions such as special placement, shielding or installation of a pressure guard or a safety valve are taken when the flowmeter is mounted.

Note

Install the sensor in well-supported pipelines in order to support the weight of the flowmeter.

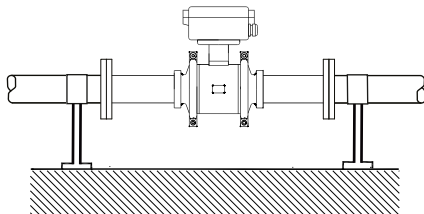

4.2 Determining a location

Note

The sensor must always be completely filled with liquid.

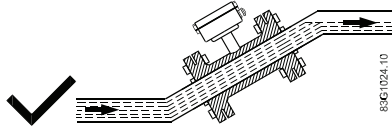

Figure 4-1 Correct installation with filled pipes

- Avoid the following installations
 - Installation at the highest point in the pipe system
 - Installation in vertical pipes with free outlet

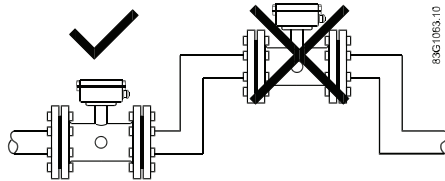

Figure 4-2 Wrong installation at high point

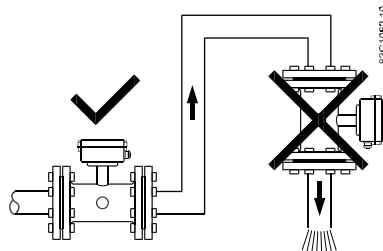
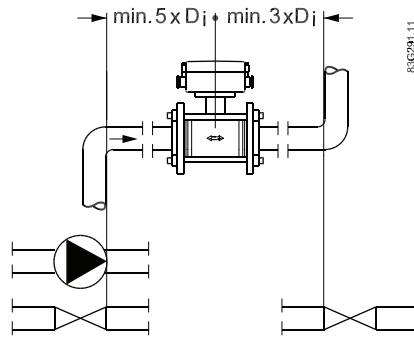

Figure 4-3 Correct installation at low point before outlet

Inlet and outlet conditions

To achieve accurate flow measurement it is essential to have straight lengths of inlet and outlet pipes and a certain distance to pumps and valves.

It is also important to centre the flowmeter in relation to pipe flanges and gaskets.



Note

Empty pipe detection

For applications with empty pipe detection, the sensor can be tilted 45°, as shown above.

4.3 Installation in partially filled pipes

Installation in partially filled pipes

For partially filled pipes or pipes with downward flow and free outlet the flowmeter should be located in a U-tube.

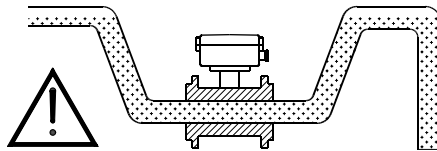

Installation in large pipes

The flowmeter can be installed between two reducers (for example DIN 28545). At $\alpha \leq 8^\circ$ the following pressure drop curves apply. The curves are applicable to water.

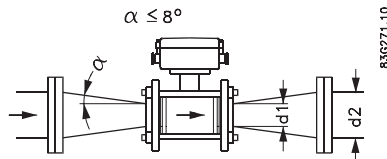

Installing/Mounting

4.3 Installation in partially filled pipes

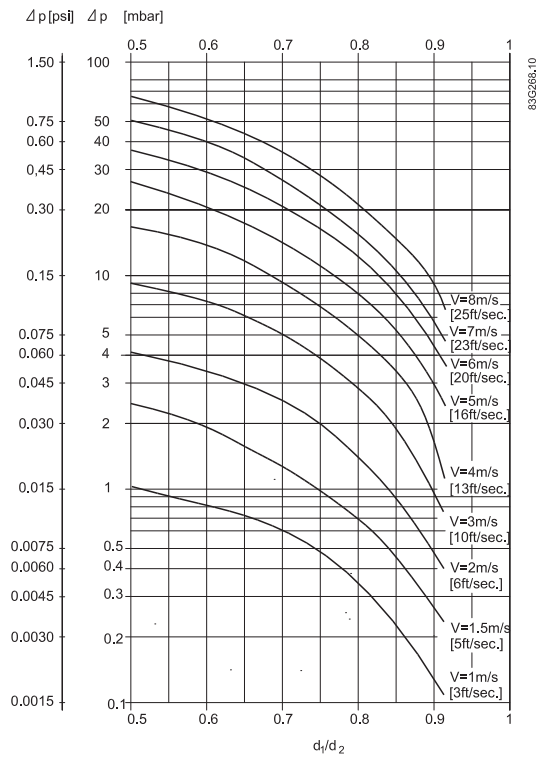

Example:

A flow of 3 m/s (v) in a sensor with a diameter reduction from DN 100 to DN 80 ($d_1/d_2 = 0.8$) gives a pressure drop of 2.9 mbar.

4.4 Orienting the sensor

The sensor operates in all orientations, but Siemens has the following recommendations:

- Vertical installation with an upwards flow

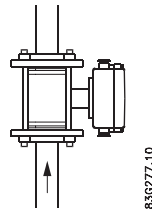

Figure 4-4 Vertical orientation, upwards flow

NOTICE

Abrasive liquids / liquids containing solid particles

A vertical installation minimizes wear and deposits in the sensor

Note

Gas/air bubbles in the liquid

A vertical installation minimizes any negative effect of gas/air bubbles in the liquid

- Horizontal installation, terminal box upwards or downwards

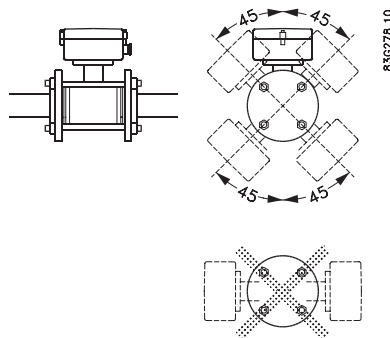

Figure 4-5 Horizontal installation, various terminal box positions

NOTICE

Do NOT mount the sensor with the terminal box sideways

This will position the electrodes at the top where there is possibility for air bubbles and at the bottom where there is possibility for mud, sludge, sand etc.

Installing/Mounting

4.5 Mounting MAG 1100/1100 HT

- Self-draining installation, minimum incline of 15° to the horizontal plane

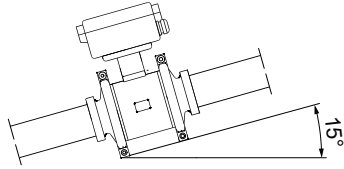

Note

3A and EHEDG certification

For the hygienic certifications 3A and EHEDG it is required to mount the sensor either vertically or with the shown incline of at least 15°

4.5 Mounting MAG 1100/1100 HT

- Install the sensor in rigid pipelines in order to support the weight of the meter.
- Center the connecting pipelines axially in order to avoid turbulent flow profiles.
- Use proper gaskets according to liner type

Remove liner protectors before installing the flow meter

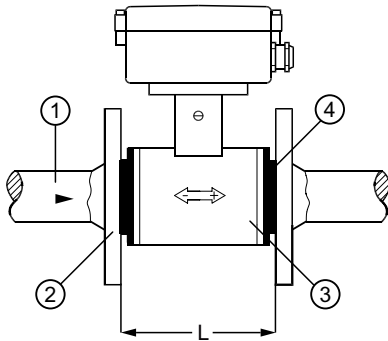

1. Existing pipe
2. Flange
3. Sensor
4. Gaskets
5. Sensor length incl. gaskets

Tightening

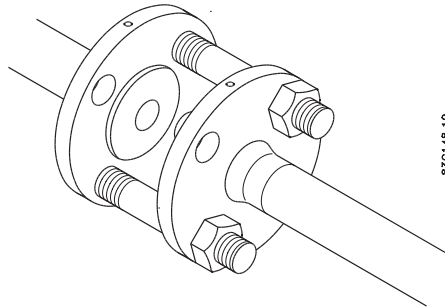
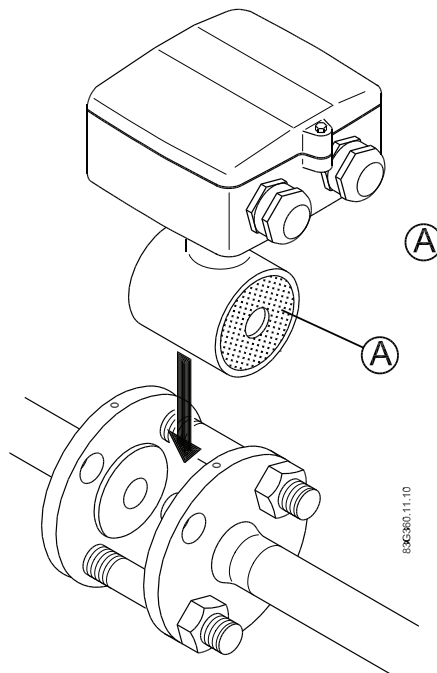

Figure 4-6 First place three stay-bolts to locate the sensor

These should be tightened gently, making sure that each gasket fits exactly into its recess at either end of the sensor



The remaining flange bolts can now be inserted and tightened using about 25% of the actual tightening torque, see table below.

Installing/Mounting

4.5 Mounting MAG 1100/1100 HT

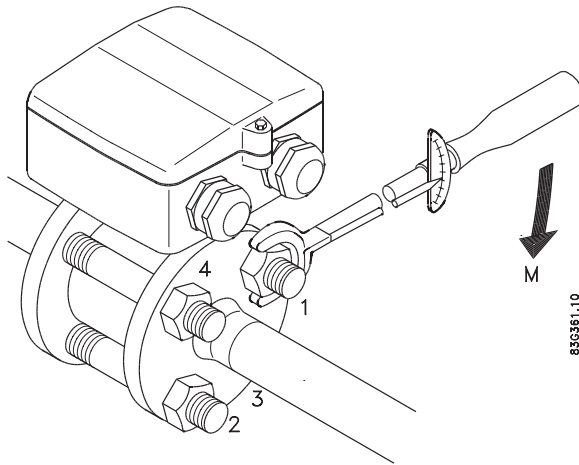

The bolts must be tightened using up to 50% of the max. tightening torque for the pipe dimensions stated. The max. tightening torque for different size pipes is given in the table.

The bolts must now be cross-tightened in the sequence shown, using up to 100% torque.

DN	M _A [N _m]
2	13
3	13
6	13
10	13
15	16
25	30
40	54
50	90
65	90
80	90
100	115

10 Nm - 1 kpm

NOTICE

Do not use sharp objects to remove the blanks as this can damage the liner!

Vibrations

Avoid strong vibrations.

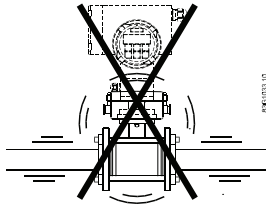

Figure 4-7 Avoid vibrations

CAUTION

In applications with strong vibrations, Siemens recommends remote mounting of the transmitter!

4.6 Mounting MAG 1100 F

The MAG 1100 F sensor has an integrated clamp connection and is designed for installation between two adapters, which are supplied separately. The adapters are available for a variety of standards according to: ISO, DIN, SMS, BS and DS, for direct welding into dairy pipes or with clamp- or threaded fittings.

At assembly, a gasket is located in the recess in the face of the adapter, and the adapter is then fastened to the MAG 1100 F sensor with a clamp ring.

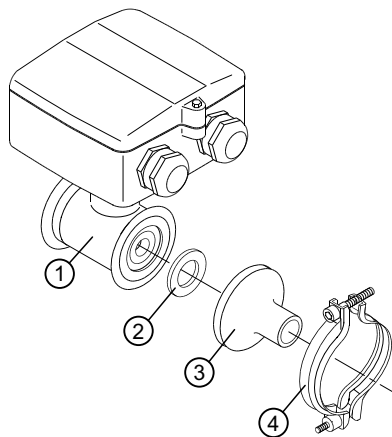

- ① Sensor
- ② Gasket
- ③ Process connection adapter
- ④ Clamp ring

Note

In order to meet the 3A Sanitary Standard the sensor must be installed as a remote unit.

Note

To obtain optimum accuracy and hygienic conditions, it is important that the sensor and the pipes are correctly aligned around their centerline, fittings must be perpendicular to the pipeline and upstream pipelines must be straight without curves.

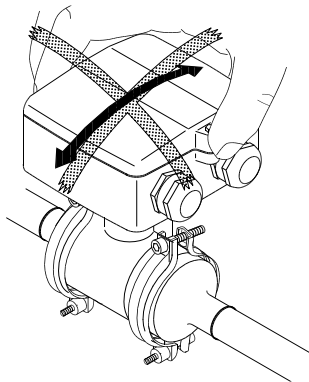

NOTICE

Damage to the liner

Turning the sensor around the adapter centre line after the clamp rings have been fastened will damage the liner. The sensor may therefore only be turned when the clamp rings have either been removed or completely loosened.

4.6.1 Mounting with a welding type adapter

To mount a MAG 1100 F with welding type adapters, follow these steps:

1. Cut a piece out of the pipeline equal to the built-in length "L".
2. Assemble the sensor and the adapters with the clamp rings. Leave the gaskets off.
3. Mount the sensor and stitch weld the adapters to the pipe.
4. Remove the clamp rings and dismount the sensor.
5. Ensure that the adapters are firmly welded to the pipe.
6. Remount the sensor with gaskets and clamp rings.

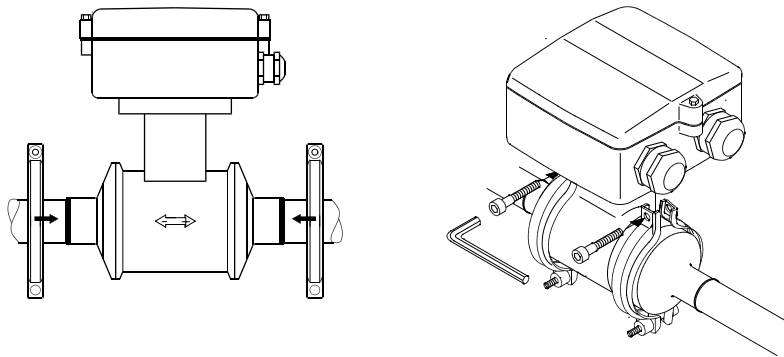

4.6.2 Mounting with a clamp type adapter

To mount a MAG 1100 F with clamp type adapters, follow these steps:

1. Prepare the pipeline with a suitable fitting.
2. Assemble the sensor and adapters together with the gaskets.
3. Place the clamp rings around the clamp connections between the adapters and pipeline.
4. Close and tighten the clamp rings.

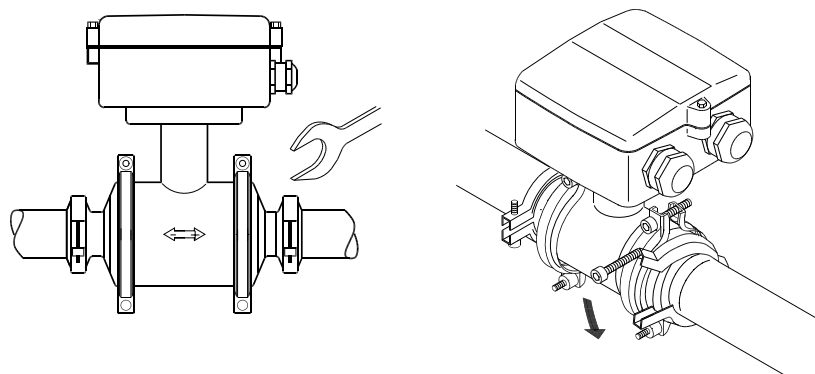

4.6.3 Mounting with a threaded type adapter

To mount a MAG 1100 F with threaded type adapters, follow these steps:

1. Prepare the pipeline with a suitable fitting.
2. Assemble the sensor and adapters together with the gaskets.
3. Tighten the threaded connectors by using a C-spanner.

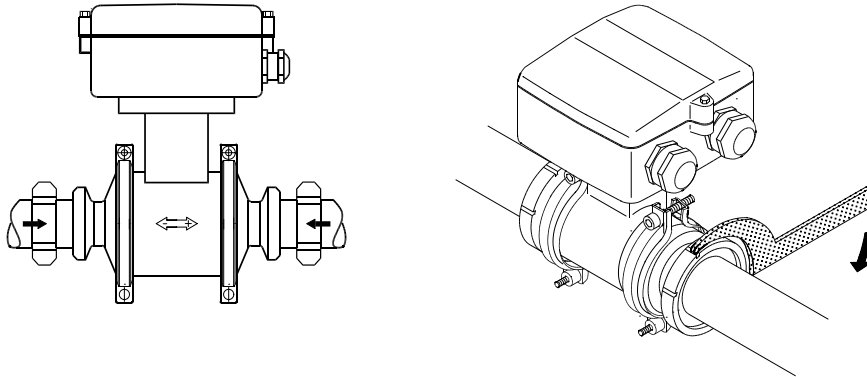

4.7 Torques values

Note

Torque values are calculated on the basis of use of gaskets.

DN mm/inch	Nm
2 / 1/12	13
3 / 1/8	13
6 / 1/4	13
10 / 3/8	13
15 / 1/2	16
25 / 1	30
40 / 1 1/2	54
50 / 2	90
65 / 2 1/2	90
80 / 3	90
100 / 4	115

4.8 Potential equalization

To obtain optimum results from the measuring system, the sensor must have the same electrical potential as the liquid being measured.

Electrically
conductive
piping

Graphite

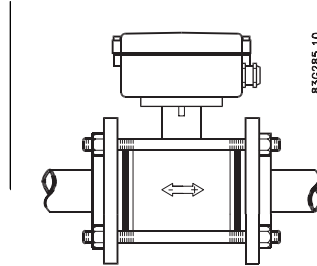

Potential equalization with electrically
graphite gaskets

EPDM or PTFE gaskets

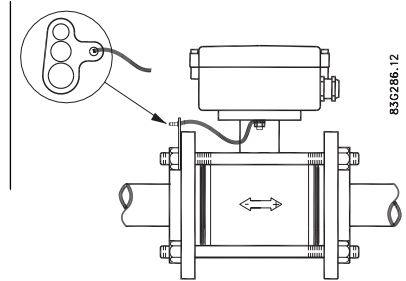

Potential equalization using earth strap
supplied

Electrically
non-conductive
piping

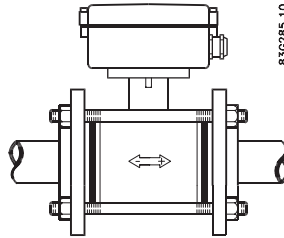

Potential equalization with electrically
conductive graphite gaskets

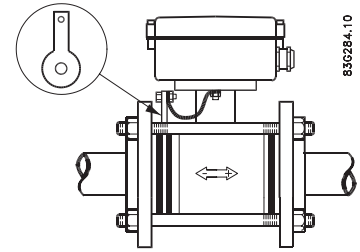

Potential equalization using separate
potential equalization ring

NOTE

For unidirectional flow use two ground-
ing rings

NOTICE

For sizes DN 2-10 with Hastelloy or stainless steel adaptors potential equalization is done
ensured through adaptors

Cathodic protection

Special attention must be paid to systems with cathodic protection



WARNING
Use in hazardous area!

Cathodic pipe protection is not allowed in hazardous areas

- Isolate the sensor from cathodic protected pipes using insulated bolts.
- Use bypass cable between the mating flanges.

Note

Remote mounted sensor versions

If the above is not acceptable, remote mounted sensors can alternatively be connected as follows:

- Connect coil current cable shield at sensor end via a 1.5 μ F condensator
- Make sure that electrode cable shield is not connected at both ends

Connecting

The following contains a short description of how to connect a remote mounted sensor to transmitter types:

- SITRANS F M MAG 5000 / 6000 (standard versions)
- SITRANS F M MAG 6000 19" with Safety barrier
- SITRANS F M MAG 6000 I Ex de

For more information, for example about wiring of power supply and outputs, refer to the operating instructions for the respective transmitters.

Before connecting

- Check that the serial numbers on the sensor and the SENSORPROM® unit are identical.

5.1 General safety requirements

WARNING

The pertinent regulations must be observed for electrical installation.

- Never install the device with the mains voltage switched on!
- Danger of electric shock!
- The electrodes and magnetic current line may only be connected when the device is not connected to the power supply.
- If the housing is under voltage (power supply), the cover may be unscrewed by qualified personnel only.

WARNING

Mains supply from building installation Class II

A switch or circuit breaker (max. 15 A) must be installed in close proximity to the equipment and within easy reach of the operator. It must be marked as the disconnecting device for the equipment.

Note

Hazardous area applications

Special requirements apply to the location and interconnection of sensor and transmitter. See Installation in hazardous area (Page 11).

 **WARNING**

Terminal box

Before opening the terminal box check that:

- No explosion hazard exists
- All connection leads are potential free

 **WARNING**

Grounding

The mains protective earth wire must be connected to the PE terminal in accordance with the diagram (class 1 power supply)

Mechanical counters

When mounting a mechanical counter to terminals 57 and 58 (active output), a 1000 μF capacitor must be connected to terminals 56 and 58. Capacitor + is connected to terminal 56 and capacitor - to terminal 58.

Output cables

If long cables are used in electrically noisy environments, it is recommended to use screened cables.

Electrode cables

Dotted connections are only to be made when using special electrode cables.

 **WARNING**

National requirements

Observe country-specific installation directives for field wiring.

Cable specifications

- Only use cables with at least the same degree of protection as the sensor to install the sensor.
- The line length from the cable gland to the terminals must be kept as short as possible. Line loops in the terminal box must be avoided.
- To guarantee the IP67 degree of protection, use cables with the required specifications.

 **WARNING**

Protective conductor terminal

The required cable is min. AGW16 or 1.5 mm² Cu.

 **WARNING**

Wire insulation

For field wiring installation: Ensure that the national requirements of the country in which the flowmeters are installed is met.

5.2 Remote installation

Note

Remote installation only

The following applies to remote installation of MAG 5000 / 6000 or MAG 6000 I.

Connecting

5.2 Remote installation

1. Unscrew and remove terminal box lid.

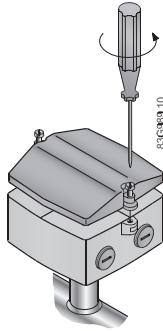

2. Mount the two terminal blocks as shown and insert electrode cable plug ① (terminals 82, 0 and 83) and coil cable plug ② (terminals 85 and 86).

Terminals electrode cable: 82, 0 and 83

Terminals special electrode cable: 84, 83, 0, 82 and 81

Terminals coil cable: 85; 86

Note

Special electrode cable

Special electrode cable must be connected to terminals 84, 83, 0, 82 and 81.

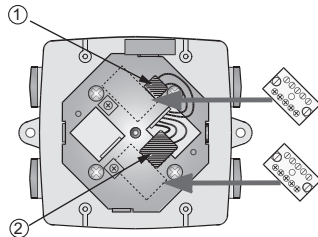
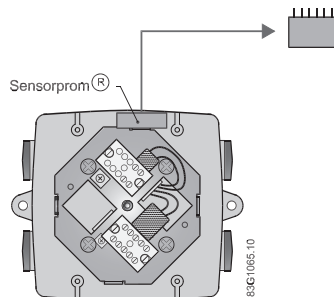

Figure 5-1 Terminal box without blocks

3. Remove SENSORPROM® unit from sensor and mount it on connection plate in transmitter, see relevant transmitter operating instructions.



4. Fit the ½" NPT or M20 cable glands for supply and output cables.

5. Fit and connect electrode and coil cables as shown below.

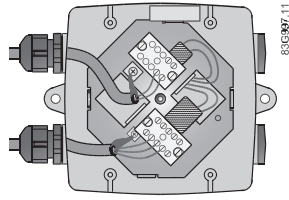

Power supply
Transmitter

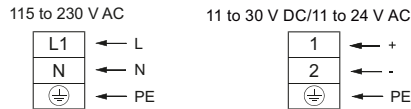

Outputs

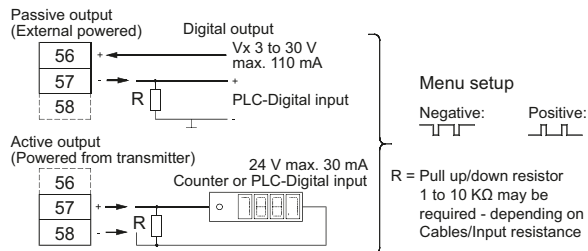
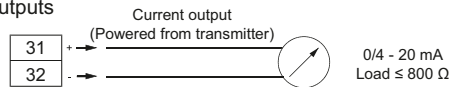

Relay output

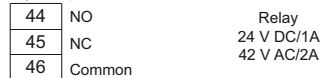

Digital input

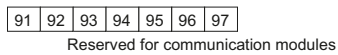
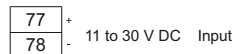

Sensor connection

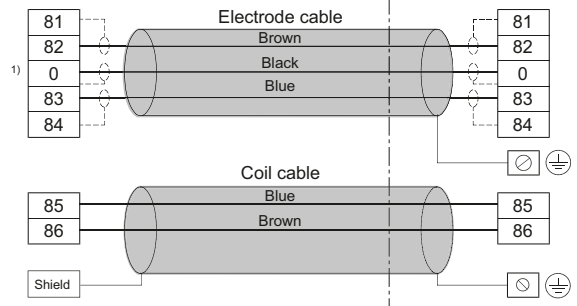

1) Note:
Special cable with individual wire shields (shown as dotted lines) are only required when using empty pipe function or long cables.

⚠ CAUTION

Unscreened cable ends

Keep unscreened cable ends as short as possible.

⚠ CAUTION

Prevent interference

Separate electrode and coil cables to prevent interference.

⚠ WARNING

Use in hazardous area

Connect mains protective earth to the PE terminal in accordance with the above diagram in order to obtain potential equalization.

6. Tighten cable glands well to obtain optimum sealing. The cable entry gasket must obtain firm contact with the cable.

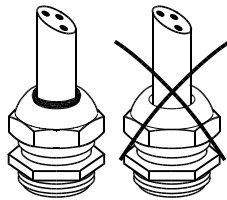

7. Remount terminal box lid.

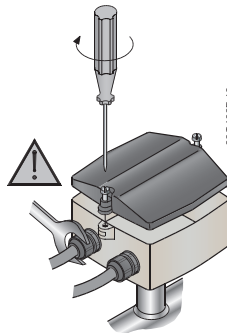

5.3 Installation check

The meter is now ready to go into normal operation - for commissioning and setting of parameters refer to the relevant transmitter manual.

Before commissioning it must be checked that:

- The device has been installed and connected in accordance with the guidelines provided previous in this chapter and in Installing/Mounting (Page 19).

5.4 Potting

The sensor can be potted with silicon dielectric gel (non-toxic, transparent and self-healing gel)

NOTICE

Electrical connections

Do **not** pot meter before electrical connections have been made.

- Mix the two components of the potting kit well and pour into terminal box.
- Let cure for approximately 24 hours at approximately 25°C (77°F). Curing time increases by 100% per -10°C (-18°F).

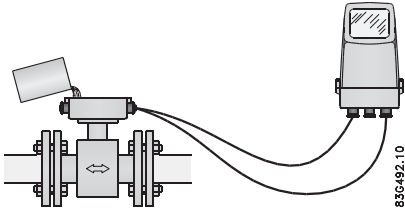

Horizontal orientation

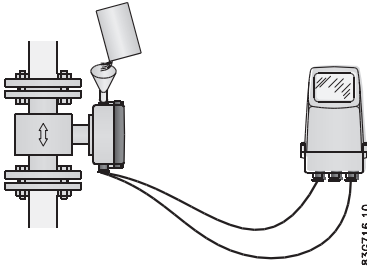

Vertical orientation

Note

Gel can be penetrated with test instruments or be removed in case of cable replacement.

Service and maintenance

6.1 Maintenance

The device is maintenance-free. However, a periodic inspection according to pertinent directives and regulations must be carried out.

An inspection can include check of:

- Ambient conditions
- Seal integrity of the process connections, cable entries, and cover screws
- Reliability of power supply, lightning protection, and grounds

NOTICE

Repair and service must be carried out by Siemens authorized personnel only.

Note

Siemens defines flow sensors as non-repairable products.

6.2 Recalibration

Siemens A/S Flow Instruments offers to recalibrate the sensor. The following calibration is offered:

- Standard matched pair calibration
- Customer-specified calibration up to 10 points
- Customer-witnessed calibration

Note

For recalibration the memory unit must always be returned with the sensor.

6.3 Unit repair

NOTICE

Repair and service must be carried out by Siemens authorized personnel only.

Note

Siemens defines flow sensors as non-repairable products.

6.4 Technical support

If you have any technical questions about the device described in these Operating Instructions and do not find the right answers, you can contact Customer Support:

- Via the Internet using the **Support Request**:
Support request (<http://www.siemens.com/automation/support-request>)
- Via Phone:
 - Europe: +49 (0)911 895 7222
 - America: +1 423 262 5710
 - Asia-Pacific: +86 10 6475 7575

Further information about our technical support is available on the Internet at Technical support (<http://support.automation.siemens.com/WW/view/en/16604318>)

Service & Support on the Internet

In addition to our documentation, we offer a comprehensive knowledge base online on the Internet at:

Service and support (<http://www.siemens.com/automation/service&support>)

There you will find:

- The latest product information, FAQs, downloads, tips and tricks.
- Our newsletter, providing you with the latest information about your products.
- Our bulletin board, where users and specialists share their knowledge worldwide.
- You can find your local contact partner for Industry Automation and Drives Technologies in our partner database.
- Information about field service, repairs, spare parts and lots more under **Services**.

Additional Support

If you have additional questions about the device, please contact your local Siemens representative and offices at:

Local contact person (<http://www.automation.siemens.com/partner>)

6.5 Return procedures

Enclose the delivery note, the cover note for return delivery and the declaration of decontamination form on the outside of the package in a well-fastened clear document pouch.

Required forms

- **Delivery Note**
- **Cover Note for Return Delivery** with the following information
Cover note (<http://support.automation.siemens.com/WW/view/en/16604370>)
 - product (ordering number)
 - number of devices or spare parts returned
 - reason for the return
- **Declaration of Decontamination**
Declaration of Decontamination (http://pia.khe.siemens.com/efiles/feldg/files/Service/declaration_of_decontamination_en.pdf)
With this declaration you certify that the returned products/spare parts have been carefully cleaned and are free from any residues.
If the device has been operated together with toxic, caustic, flammable or water-damaging products, clean the device before return by rinsing or neutralizing. Ensure that all cavities are free from dangerous substances. Then, double-check the device to ensure the cleaning is completed.
We shall not service a device or spare part unless the declaration of decontamination confirms proper decontamination of the device or spare part. Shipments without a declaration of decontamination shall be cleaned professionally at your expense before further proceeding.

You can find the forms on the Internet and on the CD delivered with the device.

6.6



Disposal

In accordance with EU directive 2002/96/EC, it is not allowed to dispose of the device using municipal waste disposal services.

Exact instructions on how to dispose of the device can be found in the disposal declaration of the device. Contact your local Siemens contact (<http://www.automation.siemens.com/partner>) for further information

Alternatively Siemens Flow Instruments will accept back and dispose of the old instrument at no cost. Follow the return procedures of Siemens Flow Instruments described in chapter: Return procedures (Page 42)

Troubleshooting

7.1 Improving the application

The first step in the troubleshooting procedure is to check for some easily resolved problems.

Check that:

- Sensor and SENSORPROM unit correspond (serial numbers)
- The sensor is properly installed.
- The sensor is located in a vibration-free position. Vibrations can disturb the sensor and therefore cause measurement error.
- The sensor is filled with liquid and liquid only. Air or gas bubbles in the liquid cause instability and can result in measurement errors.

Note

The liquid must be homogeneous in order to achieve high-accuracy measurements. If the liquid contains solid particles of greater density than the liquid, then these solids can precipitate, especially at low flow rates, which will cause instability in the sensor and lead to measurement errors.

Resolving problems

1. Make sure that the serial numbers on the sensor and the SENSORPROM® unit are identical.
2. Make sure that the sensor is installed as described in the installation chapter (Page 19) of the sensor Operating Instructions.
3. Flush the pipe systems and the sensor for several minutes at maximum flow rate to remove any air bubbles which may be present.

7.2 Sensor check

Requirement

To check the SITRANS F M sensors the following test instruments will be required:

- Digital Meter/Multimeter
- Megger
- (Moving Coil Meter)

Sensor check

Remove the transmitter from the sensor or remote position before making the following checks.

Coil resistance check

- Measure the coil resistance between connection numbers 85 and 86 using a digital meter. Resistance should be within range stated in Coil resistance table (Page 68).

A low reading may indicate moisture within the coil housing or shorted coil turns.

A high reading would indicate an open circuit coil.

Note

In case of deviation from nominal coil values, the sensor is damaged and must be replaced

Coil insulation check



WARNING

Potential hazard!

Only carry out a coil insulation check in non-hazardous area!

- Megger between connection number 85 and the sensor body. The resistance should be above 20 MΩ.

A low megger reading would indicate the coil insulation is breaking down. This is normally due to fluid ingress into the coil housing.

Sensors with an insulation resistance down to 1 MΩ may still work satisfactorily but this is not guaranteed.

Electrode resistance check

- Measure the electrode resistance between connections 82 and 0 with a moving coil meter. With a sensor full of fluid the resistance should be between 5 KΩ and 50 KΩ. If the sensor is empty the resistance will be infinite.
- Repeat the resistance measurements between connections 83 and 0. The results should be the same.

If the resistance is low there may be a short on the electrodes or wiring (in the case of a remote mounted transmitter). Alternatively there may be water ingress or moisture in the terminal box.

If the resistance is high and the pipe is completely full of fluid check the following:

1. Fluid is electrically conductive.
2. Electrodes are not coated with grease or any deposit.
3. Electrode circuit is not open.

4. Remote mounted transmitter has a 3 core cable with an overall shield continuously from sensor to transmitter, including junction boxes and terminal rails inside panels.
5. Shield is connected to 0 or to earth terminal (PE) on sensor.

Note

Sensors removed from line

For sensors removed from line with dry bore, use megger between terminal 82 and compression plate, and 83 and compression plate to show any water ingress behind electrodes or within enclosure.

See also

Coil resistance (Page 68)

7.3 Fluctuating process values

Question

Why do the displayed process values fluctuate when the electrode cable is moved?

Answer

There are several causes of the fluctuating process values:

- Deposits on electrodes
 - Clean the electrodes.
- Defect electrode cable
 - Replace the cable
- Incorrect cable connection
 - Connect the electrode cable (82, 83, 0 and shield) according to the instructions in Connecting (Page 33)

Note

Vibrating environments

It is recommended to use special low noise cables for sensor sizes DN 2 and DN 3 installed in vibrating environments.

Technical data

8.1 Process connections

Table 8-1 Process connections

Version	MAG 1100	MAG 1100 HT	MAG 1100 F
Nominal size			
- Ceramic	- DN 2 to 100 (1/12" to 4")	- DN 15 to 100 (½" to 4")	- DN 10 to 100 (3/8" to 4")
- PFA	- DN 10 to 100 (3/8" to 4")		- DN 10 to 100 (3/8" to 4")
Mating flanges			
EN 1092-1 (DIN 2501),	- DN 2 to 100 (1/12" to 4") (Ceramic)	- DN 15 to 100 (½" to 4")	
ANSI B 16.5 class 150 and 300 or equivalent	- DN 10 to 100 (3/8" to 4") (PFA) Option: DN 2 to 10 (1/12" to 3/8"): G½" / NPT ½" pipe connection adapters		
Weld in			
DIN 11850			- DN 10 to 100 (3/8" to 4")
ISO 2037 (SMS 3008)			- DN 10 to 100 (3/8" to 4")
Tri-Weld/BS 4825-1			- DN 10 to 100 (3/8" to 4")
Clamp type			
DIN 32676			- DN 10 to 100 (3/8" to 4")
ISO 2852 (SMS 3016)			- DN 25 to 100 (1" to 4")
Tri-Clamp/BS 4825-3			- DN 10 to 100 (3/8" to 4")
Threaded type			
DIN 11851			- DN 10 to 100 (3/8" to 4")
SMS 1145			- DN 25 to 65 (1" to 2½")

8.2 Rated operating conditions

Table 8-2 Ambient temperatures¹

Version	MAG 1100	MAG 1100 HT	MAG 1100 F
Standard Sensor	-40 to +100 °C (-40 to +212 °F)	-40 to +100 °C (-40 to +212 °F)	-40 to +100 °C (-40 to +212 °F)
Ex Sensor	-20 to +60 °C (-4 to +140 °F)	-20 to +60 °C (-4 to +140 °F)	-20 to +60 °C (-4 to +140 °F)
With compact transmitter			
MAG 5000/6000	-20 to +60 °C (-4 to +140 °F)		-20 to +60 °C (-4 to +140 °F)
MAG 6000 I	-20 to +60 °C (-4 to +140 °F)		-20 to +60 °C (-4 to +140 °F)
MAG 6000 I Ex de	-10 to +60 °C (+14 to +140 °F)		-20 to +60 °C (-4 to +140 °F)

¹ Conditions also dependent on liner characteristics

Table 8-3 Media temperature

Version	MAG 1100	MAG 1100 HT	MAG 1100 F
Ceramic	-20 to +150 °C (-4 to +302 °F) <i>MAG 1100 Ex</i>	-20 to +200 °C (-4 to +392 °F) <i>MAG 1100 Ex</i>	-20 to +150 °C (-4 to +302 °F) <i>MAG 1100 Ex</i>
PFA	-20 to +150 °C (-4 to +302 °F) Suitable for steam sterilization at 150 °C (302 °F)	-20 to +180 °C (-4 to +356 °F)	-20 to +150 °C (-4 to +302 °F) Suitable for steam sterilization at 150 °C (302 °F)

8.3 Temperature shock

Table 8-4 Temperature shock

Version	MAG 1100	MAG 1100 HT	MAG 1100 F
Ceramic Duration ≤ 1 min, followed by 10 min rest	DN 2 and 3 (1/12" and 3/8"): No limitations DN 6, 10, 15 and 25: Max ΔT ≤ 80 °C/min (1/4", 3/8", 1/2" and 1"): Max ΔT ≤ 144 °F/min DN 40, 50 and 65: Max ΔT ≤ 70 °C/min (1 1/2", 2", and 2 1/2"): Max ΔT ≤ 126 °F/min DN 80 and 100: Max ΔT ≤ 60 °C/min (3" and 4"): Max ΔT ≤ 108 °F/min)	DN 15 and 25: Max ΔT ≤ 80 °C/min (1/2" and 1": Max ΔT ≤ 144 °F/min) DN 40 and 50: Max ΔT ≤ 70 °C/min (1 1/2" and 2"): Max ΔT ≤ 126 °F/min DN 80 and 100: Max ΔT ≤ 60 °C/min (3" and 4"): Max ΔT ≤ 108 °F/min)	DN 10, 15 and 25: Max. ΔT ≤ 80 °C/min (3/8", 1/2" and 1"): Max. ΔT ≤ 144 °F/min DN 40, 50 and 65: Max. ΔT ≤ 70 °C/min (1 1/2", 2" and 2 1/2"): Max. ΔT ≤ 126 °F/min DN 80 and 100: Max. ΔT ≤ 60 °C/min (3", 4"): Max. ΔT ≤ 108 °F/min)
PFA	Max. ±100 °C (210 °F) momentarily		Max. ± 100 °C (212 °F) momentarily

Table 8-5 Operating pressure

Version	MAG 1100	MAG 1100 HT	MAG 1100 F
Ceramic	<ul style="list-style-type: none"> DN 2 to 65: 40 bar (1/12" to 2½": 580 psi) DN 80: 37.5 bar (3": 540 psi) DN 100: 30 bar (4": 435 psi) Vacuum 1×10^{-6} bar _{abs} (1.5 x 10 ⁻⁵ psi _{abs})	<ul style="list-style-type: none"> DN 2 to 65: 40 bar (1/12" to 2½": 580 psi) DN 80: 37.5 bar (3": 540 psi) DN 100: 30 bar (4": 435 psi) Vacuum 1×10^{-6} bar _{abs} (1.5 x 10 ⁻⁵ psi _{abs})	<ul style="list-style-type: none"> DN 10 ... 65: 40 bar (3/8" to 2½": 580 psi) DN 80: 25 bar (3": 363 psi) DN 100: 25 bar (4": 363 psi) Vacuum 1×10^{-6} bar _{abs} (1.5 x 10 ⁻⁵ psi _{abs})
PFA	20 bar to (290 psi) Vacuum 0.02 bar _{abs} (0.3 psi _{abs}) DN 80 to 100: CO ₂ pressure max. 7 bar (101.5 psi)		20 bar to (290 psi) Vacuum 0.02 bar _{abs} (0.3 psi _{abs}) DN 80 to 100: CO ₂ pressure max. 7 bar (101.5 psi)

Table 8-6 Mechanical load/Vibration

Version	MAG 1100	MAG 1100 HT	MAG 1100 F
	<ul style="list-style-type: none"> 18 to 1000 Hz random in x, y, z, directions for 2 hours according to EN 60068-2-36 Sensor: 3.17 grms Sensor with compact MAG 5000/ 6000 mounted transmitter: 3.17 grms Sensor with compact MAG 6000 I/ 6000 I Ex de mounted transmitter: 1.14 grms For compact installation with the MAG 6000 I, transmitter to be supported to avoid tension on sensor part 	<ul style="list-style-type: none"> 18 to 1000 Hz random in x, y, z, directions for 2 hours according to EN 60068-2-36 Sensor: 3.17 grms 	<ul style="list-style-type: none"> 18 to 1000 Hz random in x, y, z, directions for 2 hours according to EN 60068-2-36 Sensor: 3.17 grms Sensor with compact MAG 5000/ 6000 mounted transmitter: 3.17 grms Sensor with compact MAG 6000 I/ 6000 I Ex de mounted transmitter: 1.14 grms For compact installation with the MAG 6000 I, transmitter to be supported to avoid tension on sensor part

Table 8-7 Mechanical load/Vibration

Version	MAG 1100	MAG 1100 HT	MAG 1100 F
EMC	IP67 to EN 60529 (NEMA 4X), 1 mH ₂ O for 30 min 2004/108/EC	IP67 to EN 60529 (NEMA 4X), 1 mH ₂ O for 30 min 2004/108/EC	IP67 to EN 60529 (NEMA 4X), 1 mH ₂ O for 30 min 2004/108/EC

8.4 Design

Table 8-8 Design

Version	MAG 1100	MAG 1100 HT	MAG 1100 F
Material			
• Enclosure			
– MAG 1100	Stainless steel AISI 316L (1.4404)	Stainless steel AISI 316L (1.4404)	Stainless steel AISI 316L (1.4404)
• Terminal box			
– Standard	Fibre glass reinforced polyamide (not for Ex)	Stainless steel AISI 316 (1.4436)	Fibre glass reinforced polyamide (not for Ex)
– Option	Stainless steel AISI 316 (1.4436)		Stainless steel AISI 316 (1.4436)
• Fixing studs	Stainless steel AISI 304 (1.4301), Number and size to EN 1092-1:2001	Stainless steel AISI 304 (1.4301), Number and size to EN 1092-1:2001	Stainless steel AISI 304 (1.4301), Number and size to EN 1092-1:2001
• Gaskets			For ceramic:
- Standard	EPDM (max. 150 °C, PN 40 (max. 300 °F, 600 psi))	Graphite (max. 200 °C, PN 40 (max. 390 °F, 600 psi))	FKM/FPM with stainless steel insert (AISI 304/1.4301) (-20 ... +150 °C (-4 ... +302 °F)) EPDM (-20 ... +150 °C (-4 ... +302 °F))
- Option	Graphite (max. 200 °C, PN 40 (max. 390 °F, 600 psi)) PTFE (max. 130 °C, PN 25 (max. 270 °F, 300 psi))		For PFA: EPDM (-20 to +150 °C (-4 to +302 °F)) NBR (-20 to +100 °C (-4 to +212 °F))
• Pipe connection adapters: DN 2, 3, 6 and 10 (1/12", 1/8", 1/4" and 3/8")	• Stainless steel • Hastelloy • PVDF		

8.5 Liner

Table 8-9 Liner

Version	MAG 1100	MAG 1100 HT	MAG 1100 F
Ceramic	DN 2 and 3 (1/12" and 1/8"): Zirconium oxide (ZrO ₂) (ceramic) DN 6 to 100 (1/4" to 4"): Aluminum oxide Al ₂ O ₃	DN 15 to 100 (1/2" to 4"): Aluminum oxide Al ₂ O ₃	Aluminum oxide Al ₂ O ₃
PFA	Reinforced PFA (not for Ex)		Reinforced PFA (not for Ex)

8.6 Electrodes

Table 8-10 Electrodes

Version	MAG 1100	MAG 1100 HT	MAG 1100 F
Ceramic	DN 10 to 100 (3/8" to 4") : Platinum with gold / Titanium brazing alloy DN 2 to 6 (1/12" to 1/4"): Platinum	Platinum with gold / Titanium brazing alloy	Platinum with gold / Titanium brazing alloy
PFA	DN 10 to 15 (3/8" to 1/2"): Hastelloy C276 DN 25 to 100 (1" to 4"): Hastelloy C22		DN 10 to 15 (3/8" to 1/2"): Hastelloy C276 DN 25 to 100 (1" to 4"): Hastelloy C22

8.7 Cable entries

Table 8-11 Cable entries

Version	MAG 1100	MAG 1100 HT	MAG 1100 F
	<ul style="list-style-type: none"> • Remote installation 2 x M20 or 2 x 1/2" NPT • Compact installation <ul style="list-style-type: none"> – MAG 5000/MAG 6000: 4 x M20 or 4 x 1/2" NPT – MAG 6000 I: 2 x M25 (for supply/output) – MAG 6000 I Ex de: 2 x M25 (for supply/output) 	Remote installation 2 x M20 or 2 x 1/2" NPT	<ul style="list-style-type: none"> • Remote installation 2 x M20 or 2 x 1/2" NPT • Compact installation <ul style="list-style-type: none"> – MAG 5000/MAG 6000: 4 x M20 or 4 x 1/2" NPT – MAG 6000 I: 2 x M25 (for supply/output) – MAG 6000 I Ex de: 2 x M25 (for supply/output)

8.8 Cable data

Description

Cable for standard electrode or coil

Electrode cable, double shielded

Cable kit with standard coil cable and electrode cable double shielded (also available as low noise cable for MAG 1100 sensor)

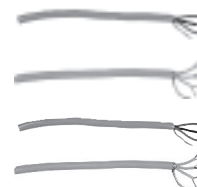

Standard applications

Table 8-12 Technical data, standard application cables

		Coil cable	Standard electrode cable
Basic data	No. of conductors	2	3
	Min. sqr. area	0.5 mm ²	0.2 mm ²
	Shield	Yes	Yes
	Max. capacitance	N/A	350 pF/m
Max. cable loop resistance	Media temperature:		
	< 100 °C (212 °F)	40 Ω	N/A
	> 200 °C (392 °F)	6 Ω	N/A
Cable glands on sensor and transmitter	M20x1.5 gland - Cable ø 5 to 13 mm (0.20 to 0.51 inches)		
	½ NPT gland - cable ø 5 to 9 mm (0.20 to 0.35 inches)		

Special applications, for example low conductivity or electrical noise

Table 8-13 Technical data, special application cables

		Coil cable	Special electrode cable
Basic data	No. of conductors	3	3
	Sqr. area	1.5 mm ²	0.25 mm ²
	Shield	Yes	Double
	Color code	Brown, blue, black	Brown, blue, black
	Outside color	Grey	Grey
	Ext. diameter	7.8 mm	8.1 mm
	Conductor	Flexible CU	Flexible CU
	Isolation material	PVC	PVC
Ambient temperature	Flexible installation	-5 to +70°C (23 to 158°F)	-5 to +70°C (23 to 158°F)
	Non-flexible installation	-30 to +70°C (-22 to 158°F)	-30 to +70°C (-22 to 158°F)
Cable parameter	Capacity	161.50 pF/m	N/A
	Inductance	0.583 µH/m	N/A
	L/R	43.83 pH/Ω	N/A

8.9 Pressure / temperature range

The following diagrams and tables show the maximum allowable working pressure at various working temperatures. For maximum allowable working pressure (MAWP) at 20 °C and at maximum working temperature, see the nameplate on the device.

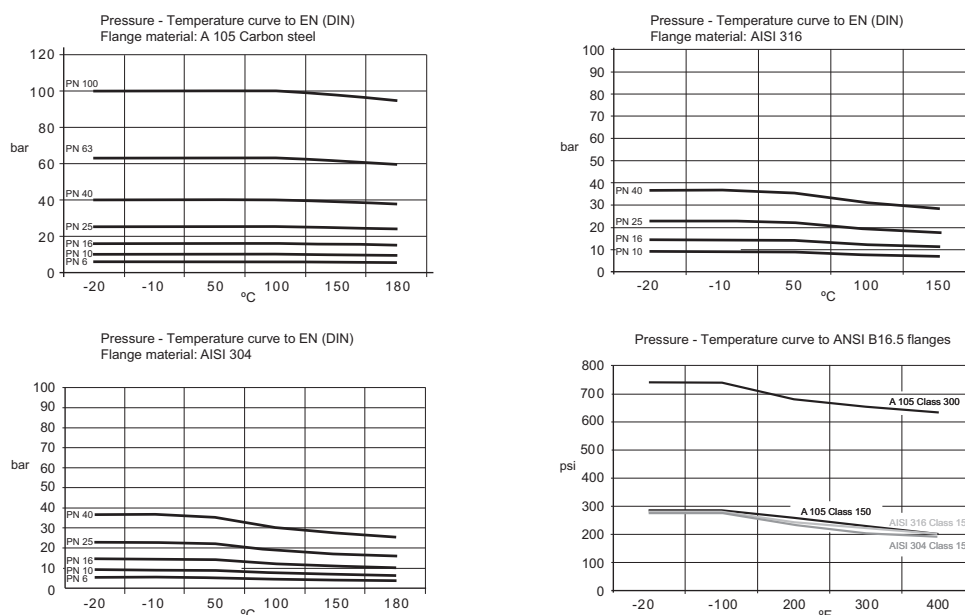

Table 8-14 Metric measures (pressure in bar) - Sizes 25 mm, 40 mm and >300 mm

Flange specifications	Flange rating	Temperature (°C)			
		-5	10	50	90
EN 1092-1	PN 10	10.0	10.0	9.7	9.4
	PN 16	16.0	16.0	15.5	15.1
	PN 40	40.0	40.0	38.7	37.7
ANSI B16.5	150 lb	19.7	19.7	19.3	18.0
AWWA C-207	Class D	10.3	10.3	10.3	10.3

Table 8-15 Imperial measures (pressure in psi) - Sizes 1", 1½" and >12"

Flange specifications	Flange rating	Temperature (°F)			
		23	50	120	200
EN 1092-1	PN 10	145	145	141	136
	PN 16	232	232	225	219
	PN 40	580	580	561	547
ANSI B16.5	150 lb	286	286	280	261
AWWA C-207	Class D	150	150	150	150

8.10 Process fluid conductivity

Compact installation

Liquids with an electrical conductivity $\geq 5 \mu\text{S/cm}$.

Remote installation

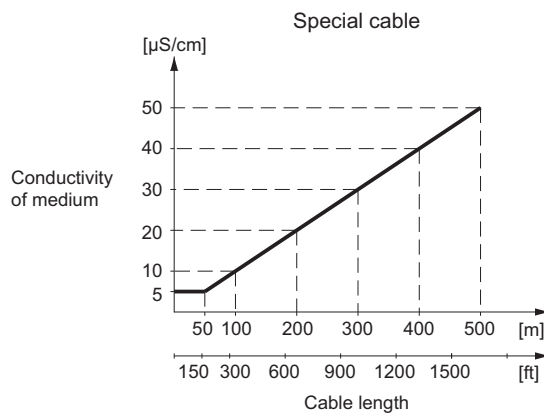
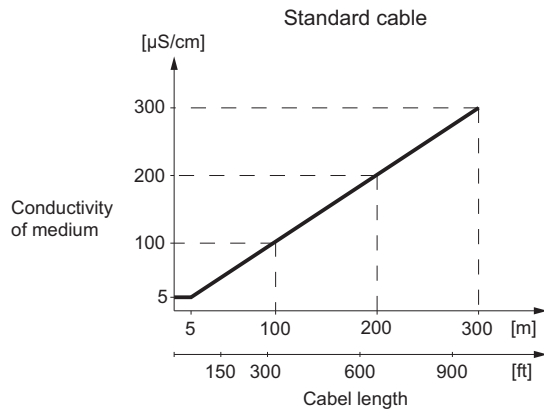

⚠ WARNING

Empty pipe detection

The installation has to fulfill the following limitations for usage of the empty pipe detection function:

- media conductivity $\geq 20 \mu\text{S/cm}$
- length of cable at remote installation ≤ 50 (150 ft)
- special shield cable must be used

Note for MAG 1100 sizes DN 2 and DN 3:

- empty pipe detection is not available
- media conductivity $\geq 30 \mu\text{S/cm}$

Note for MAG 5000/6000 CT (FW 3.03):

- empty pipe detection is not available

8.11 Dimensions and weight

MAG 1100

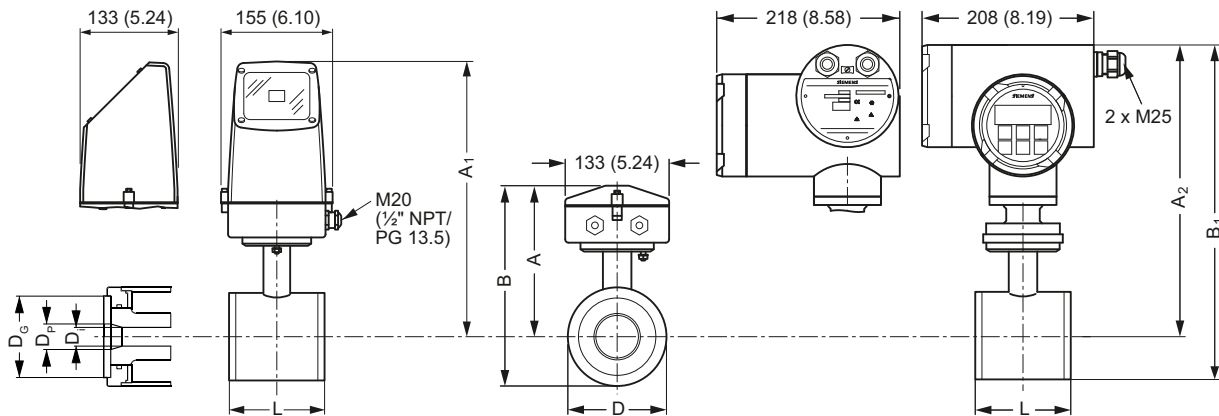

Table 8-16 Dimensions in mm

Nominal size DN	A ¹⁾	B ¹⁾	A ₁ /A ₂ ²⁾	B ₁	D	D _i	D _i (PFA)	D _p	D _e	Weight ³⁾
mm	mm	mm	mm	mm	mm	mm	mm	mm	mm	kg
2	161	186	315	340	48.7	2		17.3	34	2.2
3	161	186	315	340	48.7	3		17.3	34	2.2
6	161	186	315	340	48.7	6		17.3	34	2.2
10	161	186	315	340	48.7	10	10	13.6	34	2.2

Technical data

8.11 Dimensions and weight

Nominal size DN	A ¹⁾	B ¹⁾	A ₁ /A ₂ ²⁾	B ₁	D	D _i	D _i (PFA)	D _p	D _e	Weight ³⁾
15	161	186	315	340	48.7	15	16	17.3	40	2.2
25	169	201	323	354	63.5	25	26	28.5	56	2.7
40	179	221	333	375	84.0	40	38	43.4	75	3.4
50	188	239	342	393	101.6	50	50	54.5	90	4.2
65	198	258	351	412	120.9	65	66	68.0	112	5.5
80	204	270	357	424	133.0	80	81	82.5	124	7.0
100	217	296	370	450	159.0	100	100	107.1	150	10.0

¹⁾ 14.5 mm shorter when the stainless steel terminal box is used (Ex or high temperature 200 °C (392 °F) version)

²⁾ A2 is 3 mm shorter than A1

³⁾ With transmitter MAG 5000 or MAG 6000 installed, weight is increased by approximately 0.8 kg. With MAG 6000 I weight is increased by 5.5 kg.

Table 8-17 Dimensions in inch

Nominal size DN	A ¹⁾	B ¹⁾	A ₁ /A ₂ ²⁾	B ₁	D	D _i	D _i (PFA)	D _p	D _e	Weight ³⁾
inch	inch	inch	inch	inch	inch	inch	inch	inch	inch	lb
1½	6.34	7.33	12.40	13.39	1.92	0.08		0.68	1.34	4.8
1/8	6.34	7.33	12.40	13.39	1.92	0.12		0.68	1.34	4.8
¼	6.34	7.33	12.40	13.39	1.92	0.24		0.68	1.34	4.8
3/8	6.34	7.33	12.40	13.39	1.92	0.39	0.39	0.53	1.34	4.8
½	6.34	7.33	12.40	13.39	1.92	0.59	0.63	0.68	1.57	4.8
1	6.66	7.92	12.72	13.94	2.50	0.98	1.02	1.12	2.20	5.9
1½	7.05	8.70	13.11	14.76	3.31	1.57	1.50	1.71	2.95	7.5
2	7.40	9.41	13.47	15.47	4.00	1.97	1.97	2.15	3.54	9.2
2½	7.80	10.16	13.82	16.22	4.76	2.56	2.60	2.68	4.41	12
3	8.03	10.63	14.06	16.70	5.24	3.15	3.19	3.25	4.88	15
4	8.54	11.65	14.57	17.72	6.26	3.94	3.94	4.22	5.91	22

¹⁾ 0.57 inch shorter when the stainless steel terminal box is used (Ex or high temperature 200 °C (392 °F) version)

²⁾ A2 is 0.12 inch shorter than A1

³⁾ With transmitter MAG 5000 or MAG 6000 installed, weight is increased by approximately (1.8 lb). With MAG 6000 I weight is increased by 12.1 lb.

Table 8-18 MAG 1100 built-in length

Nominal size DN		L ¹⁾									
		EN 1092-1-201									
		EPDM		Graphite		PTFE (Teflon)		Without gasket		Grounding ring	
mm	inch	mm	inch	mm	inch	mm	inch	mm	inch	mm	inch
2...10 ¹⁾	1/12... 3/8 ¹⁾	64	2.52	66	2.60	70	2.75	64	2.52	77	3.03
15	½	65	2.56	66	2.60	70	2.75	64	2.52	77	3.03

Nominal size DN		L ¹⁾									
		EN 1092-1-201									
		EPDM		Graphite		PTFE (Teflon)		Without gasket		Grounding ring	
25	1	80	3.15	81	3.19	85	3.35	79	3.10	92	3.62
40	1½	95	3.74	96	3.78	100	3.94	94	3.70	107	4.21
50	2	105	4.13	106	4.17	110	4.33	104	4.05	117	4.61
65	2½	130	5.12	131	5.15	135	5.31	129	5.05	142	5.60
80	3	155	6.10	156	6.14	160	6.30	154	6.00	167	6.57
100	4	185	7.28	186	7.31	190	7.48	184	7.20	197	7.76

¹⁾ When earthing flanges are used, the thickness of the earthing flange must be added to the built-in length

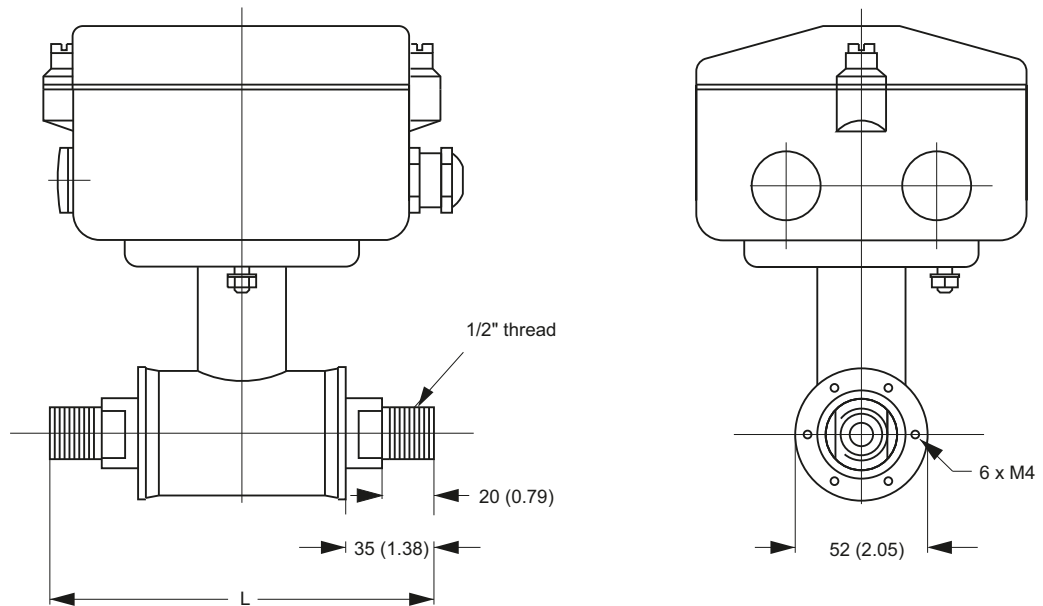

Figure 8-1 MAG 1100 with adapters

The MAG 1100 DN 2, 3, 6 and 10 (1/12", 1/8", 1/4" and 3/8") are prepared for assembly with the 1/2" pipe connections. Dimensions in mm (inch) The length "L" varies dependent on the gasket choice.

Stainless steel and Hastelloy pipe connections

Without gasket		EPDM		Graphite		PTFE	
mm	inch	mm	inch	mm	inch	mm	inch
150	5.9	150	5.9	152	6.0	156	6.1

PVDF pipe connections

PTFE	
mm	inch
133	5.2

MAG 1100 F

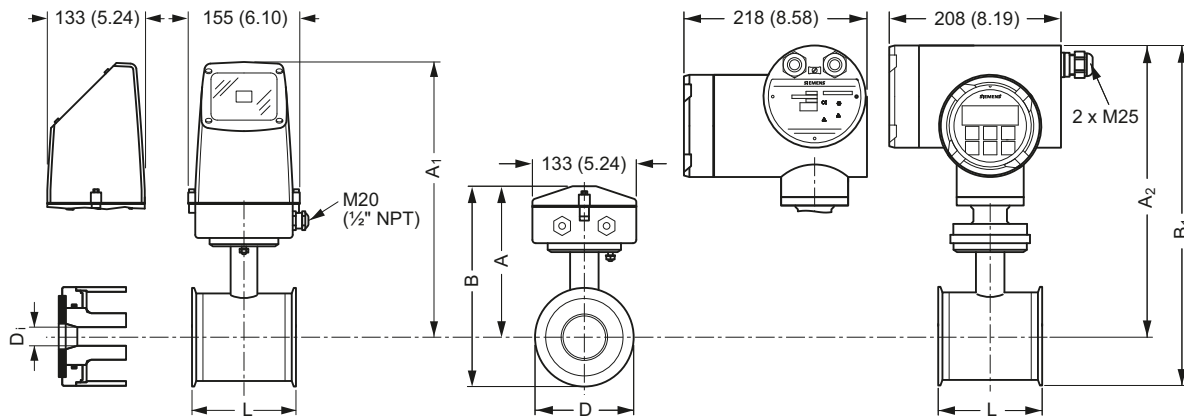

Table 8-19 Dimensions in mm

Nominal size DN	L	A	A ₁ /A ₂ ¹⁾	B ²⁾	B ₁	D	D ₁ (Al ₂ O ₃)	D ₁ (PFA)	Weight ³⁾
mm	mm	mm	mm	mm	mm	mm	mm	mm	kg
10	64	161	315	193.7	344.7	64.0	10	10	2.2
15	64	161	315	193.7	344.7	64.0	15	16	2.2
25	79	169	323	207.5	359.0	77.5	25	26	2.7
40	94	179	333	228.0	379.0	91.0	40	38	3.4
50	104	188	342	247.7	398.7	119.0	50	50	4.2
65	131	197.5	351	262.6	413.6	130.0	65	66	5.5
80	156	204	357	281.0	432.0	155.0	80	81	7.0
100	186	217	370	308.0	459.0	183.0	100	100	10.0

¹⁾ A₂ is 3 mm shorter than A₁

²⁾ 14.5 mm shorter when the stainless steel terminal box is used (Ex or high temperature 200 °C (392 °F) version)

³⁾ With transmitter MAG 5000 or MAG 6000 installed, weight is increased by approximately 0.8 kg. With MAG 6000 I weight is increased by 5.5 kg.

Table 8-20 Dimensions in inch

Nominal size DN	L	A	A ₁ /A ₂ ¹⁾	B ²⁾	B ₁	D	D ₁ (Al ₂ O ₃)	D ₁ (PFA)	Weight ³⁾
inch	inch	inch	inch	inch	inch	inch	inch	inch	lb
3/8	2.52	6.34	12.40	7.62	13.57	2.52	0.39	0.39	4.8
1/2	2.52	6.34	12.40	7.62	13.57	2.52	0.59	0.63	4.8
1	3.11	6.66	12.72	8.17	14.13	3.05	0.98	1.02	5.9
1 1/2	3.70	7.05	13.11	8.98	14.92	3.58	1.57	1.50	7.5
2	4.09	7.40	13.47	9.75	15.70	4.68	1.97	1.97	9.2
2 1/2	5.16	7.78	13.82	10.34	16.28	5.12	2.56	2.60	12.0

Nominal size DN	L	A	A ₁ /A ₂ ¹⁾	B ²⁾	B ₁	D	D ₁ (Al ₂ O ₃)	D ₁ (PFA)	Weight ³⁾
3	6.14	8.03	14.06	11.06	17.01	6.10	3.15	3.19	15.0
4	7.32	8.54	14.57	12.13	18.07	7.20	3.94	3.94	22.0

- 1) A2 is 0.12 inch shorter than A1
- 2) 0.57 inch shorter when the stainless steel terminal box is used (Ex or high temperature 200 °C (392 °F) version)
- 3) With transmitter MAG 5000 or MAG 6000 installed, weight is increased by approximately (1.8 lb). With MAG 6000 I weight is increased by 12.1 lb.

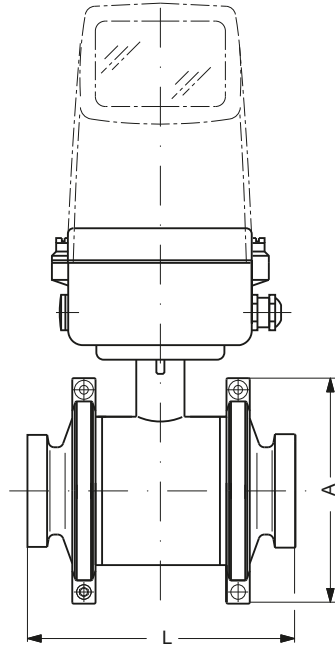

Table 8-21 MAG 1100 F built-in length

Nominal size DN		A		L ¹⁾	
mm	inch	mm	inch	mm	inch
10	3/8	99	3.90	146	5.75
15	1/2	99	3.90	146	5.75
25	1	113	4.45	161	6.34
40	1½	126	4.96	176	6.93
50	2	154	6.06	186	7.32
65	2½	165	6.50	223	8.78
80	3	200	7.87	258	10.16
100	4	225	8.86	288	11.34

- 1) The total built-in length "L" is independent of the adapter type selected.

8.12 Accessories for MAG 1100 F

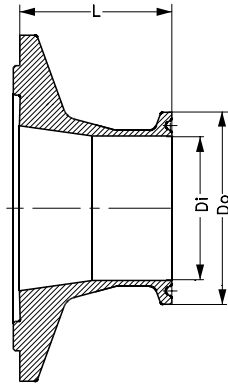

Table 8-22 Weld-in types

Adapter DN	Sensor DN	L mm	Weld-in type					
			DIN 11850		ISO 2037 (SMS 3008)		BS 4825-1 (Tri-Weld)	
			D_i mm	D_o mm	D_i mm	D_o mm	D_i mm	D_o mm
10	10	40	10.0	13.0	10.0	13.0	9.4	12.7
15	15	40	16.0	19.0	16.0	19.0	-	-
15.9	15	40	-	-	-	-	15.75	19.05
20	15	40	-	-	20.0	23.0	-	-
25	25	40	-	-	22.6	25.6	22.1	25.4
25	25	40	26.0	29.0	-	-	-	-
28	25	40	-	-	25.6	28.6	-	-
32	25	40	-	-	-	-	-	-
32	25	40	32.0	35.0	-	-	-	-
38	40	40	-	-	35.6	38.6	34.8	38.1
40	40	40	-	-	37.6	40.6	-	-
40	40	40	38.0	41.0	-	-	-	-
50	50	40	-	-	48.6	51.6	47.5	50.8
50	50	40	50.0	53.0	-	-	-	-
63.5	65	45	-	-	60.3	64.1	60.2 ¹⁾	63.5 ¹⁾
65	65	45	66.0	70.0	-	-	-	-
76	65	45	-	-	-	-	-	-
76.1	80	50	-	-	72.9	76.7	72.9	76.2
80	80	50	81.0	85.0	-	-	-	-
100	100	50	100	104	-	-	-	-
101.6	100	50	-	-	97.6	102.5	97.38 ¹⁾	101.6 ¹⁾
114.3	100	50	-	-	110.3	115.6	-	-

Table 8-23 Weld-in types

Adapter	Sensor	L	Weld-in type					
			DIN 11850		ISO 2037 (SMS 3008)		BS 4825-1 (Tri-Weld)	
DN	DN		Di	Do	Di	Do	Di	Do
mm	mm	mm	mm	mm	mm	mm	mm	mm
10	10	40	10.0	34.0	10.0	34.0	10.0	34.0
15	15	40	16.0	34.0	16.0	34.0	10.0	34.0
25	25	40	-	-	-	-	22.6	50.5
25	25	40	26.0	50.5	26.0	-	-	-
33.7	25	40	-	-	31.3	50.5	-	-
38	40	40	-	-	35.6	38.6	35.6	50.5
40	40	40	38.0	50.0	-	-	-	-
50	50	40	50.0	64.0	-	-	-	-
51	50	40	-	-	48.6	64.0	48.6	64.0
63.5	65	45	-	-	60.3	77.5	60.3 ¹⁾	77.5 ¹⁾
65	65	45	66.0	91.0	-	-	-	-
76.1	80	50	-	-	72.9	91.0	72.9	91.0
80	80	50	81.0	85.0	-	-	-	-
100	100	50	100	119.9	-	-	-	-
101.6	100	50	-	-	97.6	119.0	97.6 ¹⁾	119.0

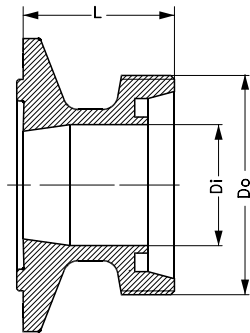

Table 8-24 Threaded type DIN 11851

Adapter	Sensor	L	Threaded type DIN 11851 ¹⁾	
DN	DN		Di	Do
mm	mm	mm	mm	mm
10	10	40	10.0	28.0
15	15	40	16.0	34.0
20	15	40	20.0	44.0
25	25	40	26.0	52.0
32	25	40	32.0	58.0
40	40	40	38.0	65.0

Technical data

8.12 Accessories for MAG 1100 F

Adapter	Sensor	L	Threaded type	
			DIN 11851 ¹⁾	
DN	DN		Di	Do
50	50	40	50.0	78.0
65	65	45	66.0	95.0
80	80	50	81.0	110.0
100	100	50	100.0	130.0

¹⁾ Only 3A used with self centering gaskets

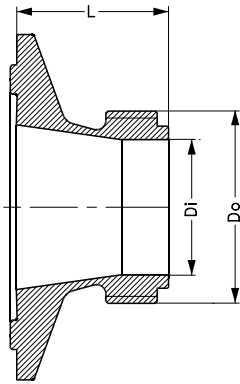

Table 8-25 Threaded type ISO 2853/BS 4825-4

Adapter	Sensor	L	Threaded type			
			ISO 2853 ¹⁾		BS 4825-4 ¹⁾	
DN	DN		Di	Do	Di	Do
mm	mm	mm	mm	mm	mm	mm
25	25	40	22.6	37.0	22.6	37.0
38	40	40	35.6	51.0	35.6	51.0
51	50	40	48.6	64.0	48.6	64.0
63.5	65	45	60.3	78.0	60.3	78.0
76.1	80	50	72.9	91.0	72.9	91.0
101.6	100	50	-	-	97.6	126.0
101.6	100	50	97.6	118.0	-	-

¹⁾ Not suitable for 3A approval

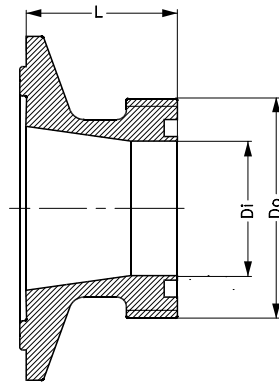

Table 8-26 Threaded type SMS 1145

Adapter	Sensor	L	Di	Do	Threaded type SMS 1145 ¹⁾
DN	DN		Di	Do	
mm	mm	mm	mm	mm	
25	25	40	22.6	40.0	
38	40	40	35.6	60.0	
51	50	40	48.6	70.0	
63.5	65	45	60.3	85.0	
76	65	45	72.0	98.0	

¹⁾ Not suitable for 3A approval

8.13 Certificates and approvals

Table 8-27 Certificates and approvals

Version	MAG 1100	MAG 1100 HT	MAG 1100 F
Calibration	Zero-point, 2 x 25 % and 2 x 90 %	Zero-point, 2 x 25 % and 2 x 90 %	Zero-point, 2 x 25 % and 2 x 90 %
Standard production calibration, calibration report shipped with sensor			
Conforms to	PED - 2014/68/EU and CRN (PFA)	PED - 2014/68/EU and CRN (PFA)	PED - 2014/68/EU
Ex approvals			
Ceramic			
• Ex sensor or Compact with MAG 6000 I Ex	ATEX, FM, CSA, IECEx, EAC Ex, NEPSI - Zone 1 Ex d e ia IIC T6 - Zone 1 Ex e ia IIC T6	ATEX, FM, CSA, IECEx, EAC Ex - Zone 1 Ex d e ia IIC T6 - Zone 1 Ex e ia IIC T6	ATEX, EAC Ex - Zone 1 Ex d e ia IIB T6 ATEX - Zone 21 Ex tD A21 IP67

Technical data

8.13 Certificates and approvals

Version	MAG 1100	MAG 1100 HT	MAG 1100 F
<ul style="list-style-type: none"> Sensor with/without MAG 5000/6000/6000 I 	FM Class 1, Div 2	FM Class 1, Div 2	FM Class 1, Div 2
<p>PFA</p> <ul style="list-style-type: none"> Sensor with/without MAG 5000/6000/6000 I 	FM Class 1, Div 2		FM Class 1, Div 2
<p>Hygienic</p> <ul style="list-style-type: none"> MAG 1100 F (Ceramic) MAG 1100 F (PFA) 			<ul style="list-style-type: none"> 3A (remote version with Polyamide terminal box) 3A (remote version with Polyamide terminal box) EHEDG (remote version with Polyamide terminal box, DN 25 to 100 (1" to 4")) Hygienic EC 1935:2004 European food contact material

Appendix

A.1 Factory settings

Dimension-dependent factory settings

Table A-1 50 Hz version

mm	DN		Fac. settings	Qmax		Unit	Volume/pulse	Pulse unit	Totalizer unit
	Inch			Min.	Max.				
2	1/12		30	3.9	113	l/h	0.1	ml	ml
3	1/8		70	6.3	254	l/h	0.1	ml	ml
6	¼		300	25.4	1017	l/h	1	l	l
10	3/8		900	70.6	2827	l/h	1	l	l
15	½		2000	159	6361	l/h	1	l	l
25	1		5000	441	17671	l/h	10	l	l
40	1½		12	1.1	45	m³/h	10	l	l
50	2		20	1.7	70	m³/h	10	l	l
65	2½		30	2.9	119	m³/h	100	l	l
80	3		50	4.5	180	m³/h	100	l	l
100	4		120	7	282	m³/h	100	l	l

Table A-2 60 Hz version

mm	DN		Fac. settings	Qmax		Unit	Volume/pulse	Pulse unit	Totalizer unit
	Inch			Min.	Max.				
2	1/12		0.13	0.01717	0.68	US GPM	1	US G	US G
3	1/8		0.31	0.02801	1.12	US GPM	1	US G	US G
6	¼		1.3	0.11	4.4	US GPM	1	US G	US G
10	3/8		4	0.31	12.4	US GPM	1	US G	US G
15	½		9	0.7	28.0	US GPM	1	US G	US G
25	1		22	1.9	77.8	US GPM	1	US G	US G
40	1½		52	4.9	199.1	US GPM	1	US G	US G
50	2		88	7.7	311.2	US GPM	1	US G	US G
65	2½		132	13.1	525.9	US GPM	1	US G	US G
80	3		220	19.9	796.7	US GPM	1	US G	US MG
100	4		528	31.1	1244.8	US GPM	1	US G	US MG

Appendix

A.2 Coil resistance

Dimension-dependent batch and pulse output settings

Table A-3 50 Hz version

mm	DN	Inch	Qmax	
			Min.	Max.
2		1/12	-	-
3		1/8	-	-
6		¼	-	-
10		3/8	-	-
15		½	-	-
25		1	409 µl	10.7 m ³
40		1½	1.05 ml	27.5 m ³
50		2	1.46 ml	42.9 m ³
65		2½	2.31 ml	72.5 m ³
80		3	3.71 ml	110 m ³
100		4	5.79 ml	172 m ³

Table A-4 60 Hz version

mm	DN	Inch	Qmax	
			Min.	Max.
2		1/12	0.00000095	25
3		1/8	0.00000156	41
6		¼	0.00000622	163
10		3/8	0.00001729	453
15		½	0.0000389	1019
25		1	0.000108	2833
40		1½	0.000277	7252
50		2	0.000433	11331
65		2½	0.000730	19149
80		3	0.00111	29007
100		4	0.00173	45325

A.2 Coil resistance

Table A-5 Coil resistance [Ω]

DN	Inch	MAG 1100, MAG 1100F	
		Resistance	Tolerance
2	1/12	104	+/- 5
3	1/8	104	+/- 5
6	1/4	99	+/- 17

		MAG 1100, MAG 1100F	
10	3/8	99	+/- 17
15 ¹⁾	1/2	91	+/- 9
25	1	91	+/- 17
40	1 1/2	91	+/- 9
50	2	91	+/- 9
65	2 1/2	99	+/- 17
80	3	91	+/- 17

¹⁾ On MAG 1100 DN 15 produced as from May 1999 the coil resistance must be 86 ohm, +8/-4 ohm.

Note

Reference values

- All resistance values are at 20 °C
- The resistance changes proportionally 0.4% / °C

A.3 Ordering of spare parts

Ensure that your ordering data is not outdated. The latest ordering data is always available on the Internet: Catalog process instrumentation (<http://www.siemens.com/processinstrumentation/catalogs>)

Index

A

Abrasive liquids, 23
Add-on modules, (See Communication module)
Ambient temperatures, 50

C

Cable entries, 53
Cable specifications, 35, 53
Cathodic protection, 31
Certificates, 13
Certificates and approvals, 65
Coil insulation check, 46
Coil resistance check, 46
Communication modules, 15
Compliance, 9
Contact person, 7
Customer Support Hotline, 42

D

Decontamination, 42
Design, 16, 52
Device
 Identification, 6
 Inspection, 6
Dimensions, 57, 60
Document history, 5

E

Electrical connection
 Cable specifications, 35
 In hazardous area, 33
 Remote installations, 35
 Safety instructions, 33
Electrode
 Material, 16
Electrode resistance check, 46
Electrodes, 53
Empty pipe detection, 21

F

Factory settings
 Dimension dependent, 67
FAQ
 Fluctuating process values, 47

G

Gas / Air bubbles, 23

H

Hazardous area
 Temperature specifications, 12
Hazardous area
 Approvals, 11
 Electrical connection, 33
 Special conditions, 12
Horizontal Pipes, 23
Hotline, 42

I

Inlet / outlet conditions, 20
Installation
 Horizontal Pipes, 23
 in U-tube, 20
 Indoor/outdoor, 19
 Large pipes, 21
 Location in system, 20
 Mounting of sensor, 24
 Partially filled pipes, 21
 Pipes with free outlet, 20
 Remote, 35
 Safety instructions, 19
 Self-draining, 24
 Vertical pipes, 23
Internet
 Contact person, 7, 42
 Flow documentation, 7
 Support, 42
Intrinsically safe data, 11
Items supplied, 5

L

Laws and directives, 9
Liner, 52
 Material, 16

M

Mains supply, 33
Maintenance, 41
Material compatibility, 9
Measurement principle, 17
Mechanical load, 51
Mounting, (See Installation)

O

Operating pressure, 51

P

Potting, 39
Pressure
 In relation to temperature, 55
 Safety instructions, 19
Process connections, 49
Process fluid
 Conductivity, 56
 Temperature, 50
Protective conductor terminal, 35
Protective earth, 35

R

Recalibration, 41
Repair, 41
Return procedures, 42

S

Safety, 9
 Instrument safety standards, 9
 Sensor installation, 19
Safety instructions
 Electrical connection, 33
Scope of delivery, 6
Sensor check, 45
Sensor orientation, 23

Service, 41, 42
Support, 42
System components, 15

T

Temperature
 Ambient, 50
 In relation to pressure, 55
 Process fluid, 50
Temperature shock, 50
Temperature specifications, 12
Theory of operation, 17

V

Vertical Pipes, 23
Vibrations, 27, 51

W

Warranty, 8
Wire insulation, 35
Wiring, (See Electrical connection)

We supply:

- **SITRANS FM Magflo**
- **SIEMENS MAG 1100**
- **SIEMENS MAG 3100**
- **SIEMENS MAG 5100**
- **SIEMENS MAG 8000**
- **other Siemens products**

Eltra Trade s.r.o. supplies full range of SIEMENS SITRANS F products with the best prices and delivery terms.

STAY UPDATED



Best prices



The fastest supply



Best level technical support



Customers in over 100 countries



To find out stock ability and delivery time to your region, please contact our manager.



info@eltra-trade.com